

Wood

041359/041360 Kommode

041359/041360 Dresser

041359/041360 Kommode

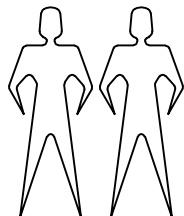

OLIVER FURNITURE A/S

Ndr. Strandvej 119 G

3150 Hellebæk

Denmark

Tel. +45 4970 7317

www.oliverfurniture.com

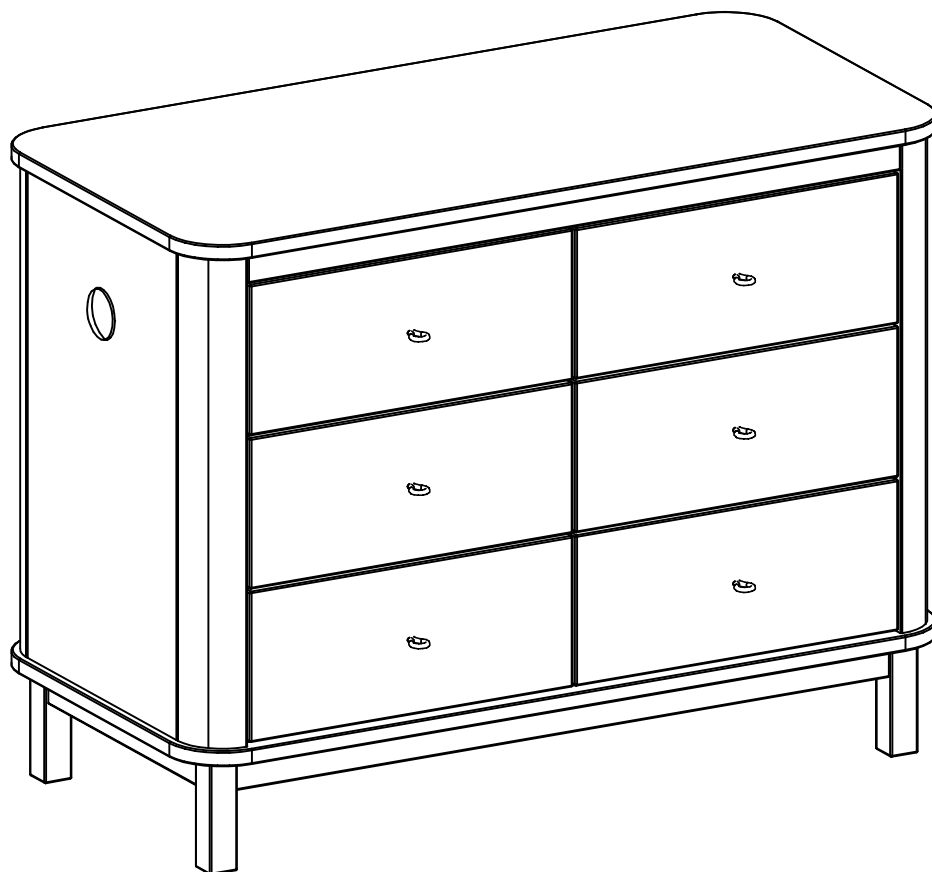

VIGTIGT - LÆS VENLIGST

Kære kunde,

Tak fordi du har valgt Oliver Furniture.

For at sikre den bedste oplevelse med dine nye møbler skal du passe godt på dem. Bemærk venligst, at Oliver Furnitures kvalitetsgaranti kun gælder, hvis nedenstående retningslinjer følges. Hvis du har spørgsmål til dine Oliver Furniture møbler, er du altid velkommen til at kontakte vores team, som gerne vil hjælpe dig med rådgivning.

Montering

Vi anbefaler, at produkterne samles på en glat og jævn overflade. Brug kartonen fra emballagen som underlag. Vær opmærksom på, at møbeldelene er meget udsatte for lakskader på hjørner og kanter, derfor skal du være meget forsigtig under monteringen.

I begyndelsen vil en let lugt være uundgåelig for ny producerede møbler. Denne lugt vil forsvinde efter et stykke tid. For at fremskynde denne proces skal du lufte oftere ud i begyndelsen ved at åbne møblernes døre og skuffer og sikre optimalt luftskifte i rummet.

Pleje og vedligeholdelse

Malede overflader er generelt sårbare og ikke ridsefaste.

Tør dine møbler af med en tør klud, efter at du har rengjort dem med en fugtig klud.

Hvis du spilder væske, bør du altid tørre det op med det samme for at undgå skader og opsvulmede møbler. Brug overfladebeskyttelse (puder eller måtter) under fugtige genstande. Placer ikke varme genstande på møblerne.

IMPORTANT - PLEASE READ

Dear Customer,

Thank you for choosing Oliver Furniture.

To ensure the best experience with your new furniture, you must take good care of it. Please note that the quality guarantee of Oliver Furniture is only valid when these guidelines are followed carefully. If you have any questions about your Oliver furniture products, you are always welcome to contact our team, who will be happy to assist you with advice.

Assembly

We recommend assembling the products on a smooth and even surface. Use the cardboard from the packaging as an underlay. Be aware that the furniture parts are very exposed to lacquer damage on the corners and edges; therefore, you must be very careful during assembly.

Initially, a slight inherent odour is unavoidable for newly produced furniture. These odours will gradually disappear after a while. To speed up this process, ventilate more often at the beginning by opening the doors and drawers of furniture and ensuring optimal air exchange in the room.

Care and Maintenance

Painted surfaces are generally vulnerable and not scratch resistant.

Wipe your furniture with a dry cloth after cleaning it with a damp cloth.

If you spill any liquid, you should always wipe it off immediately to avoid damage and swollen furniture.

Use surface protection (pads or mats) under damp objects. Don't place any hot objects on the furniture.

WICHTIG - BITTE LESEN

Lieber Kunde,

Vielen Dank, dass Sie sich für Oliver Furniture entschieden haben.

Um das beste Erlebnis mit den neuen Möbeln zu gewährleisten, müssen diese gut gepflegt werden. Bitte beachten Sie, dass die Qualitätsgarantie von Oliver Furniture nur dann gültig ist, wenn diese Richtlinien sorgfältig befolgt werden. Wenn Sie Fragen zu Ihren Oliver Furniture Möbeln haben, können Sie sich jederzeit an unser Team wenden, das Ihnen gerne mit Rat und Tat zur Seite steht.

Montage

Wir empfehlen, die Produkte auf einer glatten und ebenen Fläche zu montieren. Verwenden Sie den Karton aus der Verpackung als Unterlage.

Bitte beachten Sie, dass die Möbelstücke an den Ecken und Kanten sehr anfällig für Lackschäden sind, deshalb müssen Sie bei der Montage sehr vorsichtig sein. Bei neu produzierten Möbeln ist anfangs ein leichter Eigengeruch unvermeidlich. Dieser Geruch wird nach einiger Zeit verschwinden. Um diesen Vorgang zu beschleunigen, lüften Sie anfangs häufiger aus, indem Sie die Türen und Schubladen der Möbel öffnen und für einen optimalen Luftaustausch im Raum sorgen.

Pflege und Wartung

Lackierte Oberflächen sind im Allgemeinen empfindlich und nicht kratzfest. Nachdem Sie Ihre Möbel mit einem feuchten Tuch gereinigt haben, trocknen Sie die Oberfläche bitte mit einem trockenen Tuch wieder ab. Wenn Sie Flüssigkeit verschüttet haben, sollten Sie diese immer sofort abwischen, um Schäden und aufgequollene Möbel zu vermeiden. Verwenden Sie einen Oberflächenschutz unter feuchten Gegenständen und stellen Sie keine heißen Gegenstände auf die Möbel.

IMPORTANT - VEUILLEZ LIRE ATTENTIVEMENT

Chers clients,

Merci d'avoir choisi les meubles d'Oliver Furniture.

Pour assurer la meilleure utilisation de votre nouveau meuble, nous vous demandons de le traiter avec soin. Veuillez noter que la garantie de qualité d'Oliver Furniture est seulement valable lorsque ces instructions sont suivies attentivement. Si vous avez des questions concernant vos produits d'Oliver Furniture, vous pouvez toujours contacter notre équipe, qui sera heureuse de vous conseiller.

Assemblage

Nous recommandons d'assembler le meuble sur une surface ferme, plate et horizontale en utilisant p. ex. le carton de l'emballage. Les coins et les bords de toutes les parties du meuble sont très exposés. Soyez très prudent lors du montage afin de ne pas endommager la laque.

Au début, une légère odeur de produit est inévitable pour les meubles nouvellement fabriqués. Cette odeur disparaîtra progressivement après un certain temps. Pour accélérer ce processus, aérez souvent en ouvrant les portes et les tiroirs des meubles et en assurant une aération optimale de la chambre.

Soins et entretien

Les surfaces peintes sont généralement vulnérables et ne résistent pas aux rayures.





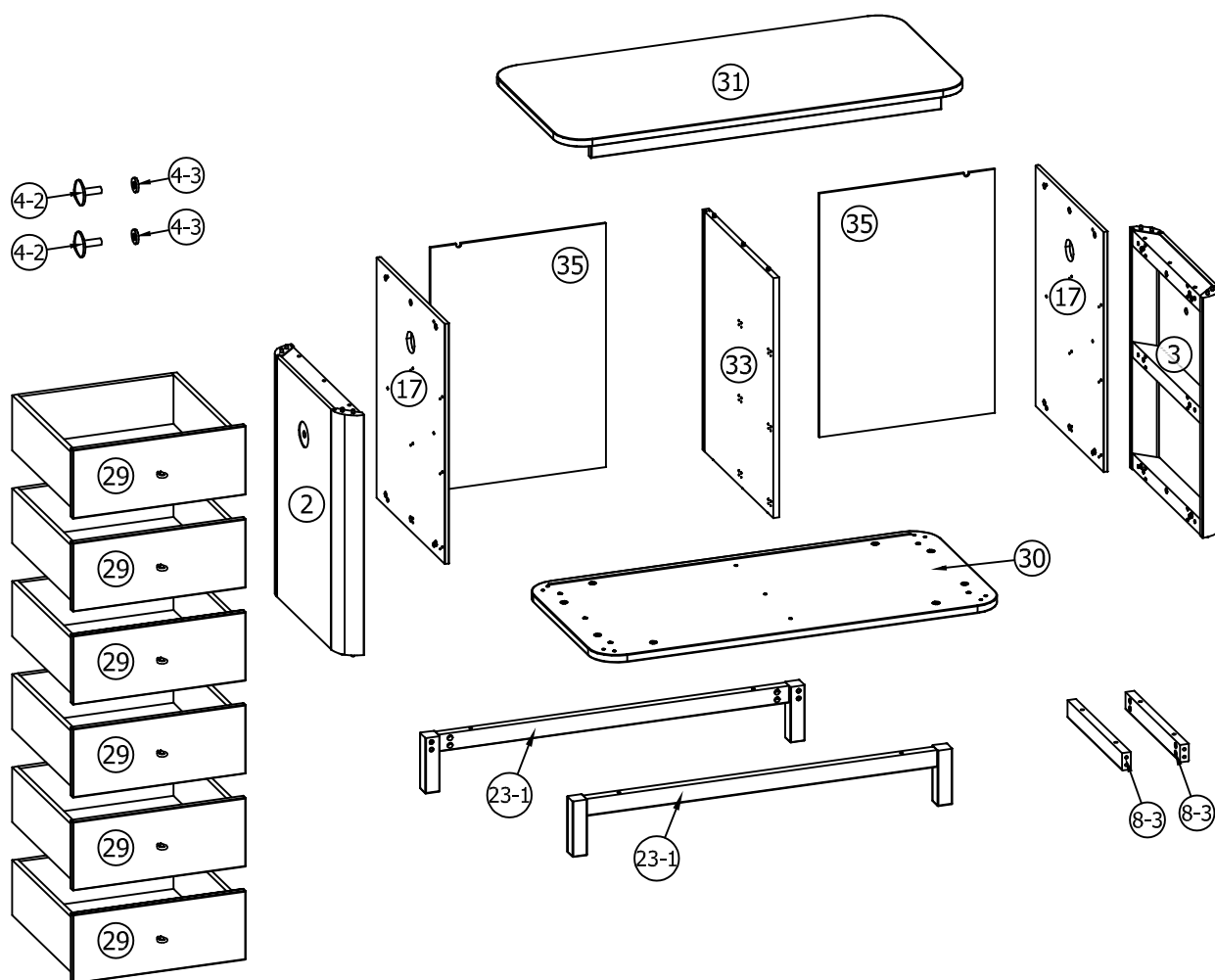

Essuyez vos meubles avec un chiffon sec après les avoir nettoyés avec un chiffon humide.

Si vous renversez un liquide, vous devez toujours l'essuyer immédiatement pour éviter que le bois gonfle et endommage le meuble.

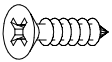
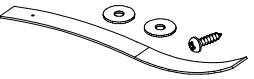

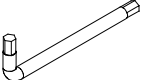
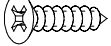
Utilisez des protections sur la surface (coussins, plateau) sous les objets humides. Ne posez pas d'objets chauds sur les meubles.

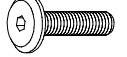
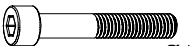
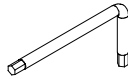
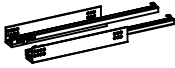
Teil-Nr. Pieces-no. Enheds. Nr.	Anzahl Quantities Antal	Colis-Nr. Package-no. Pakke nr.	Maß, mm Dimensions, mm Størrelse, mm	✓
2	1	051319	697 x 428 x 12	
3	1	051319	697 x 428 x 12	
4-2	2	051316/051317	Ø70 x 78	
4-3	2	051316/051317	Ø40 x 6	
8-3	2	051316/051317	416 x 50 x 26	
17	2	051319	697 x 522 x 12	
23-1	2	051316/051317	1096 x 162 x 42	
29	6	051318	500 x 493 x 200	
30	1	051316/051317	1176 x 580 x 22	
31	1	051316/051317	1176 x 580 x 61	
33	1	051319	697 x 522 x 18	
35	2	051319	708 x 507 x 6	

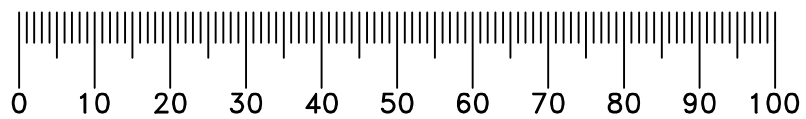

A136	 x24 Ø4x12	D39	 x2	D196	 x20 Ø15x14
D198	 x20 Ø7x34 M6 SISO	A172	 x1 6 mm	A1	 x2 Ø3,5x15
D197	 x20 M10x7,5	A82	 x12 M6x30	A232	 x8 Ø13/M8x50
A6	 x1 4 mm	E87	 x6 485 mm	A25	 x24 Ø7,8/6,2x10,5

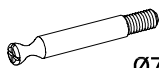

D196		x8 Ø15x14	D197		x8 M10x7,5	D198		x8 Ø7x34 M6 SISO
------	---	--------------	------	---	---------------	------	---	---------------------

1.

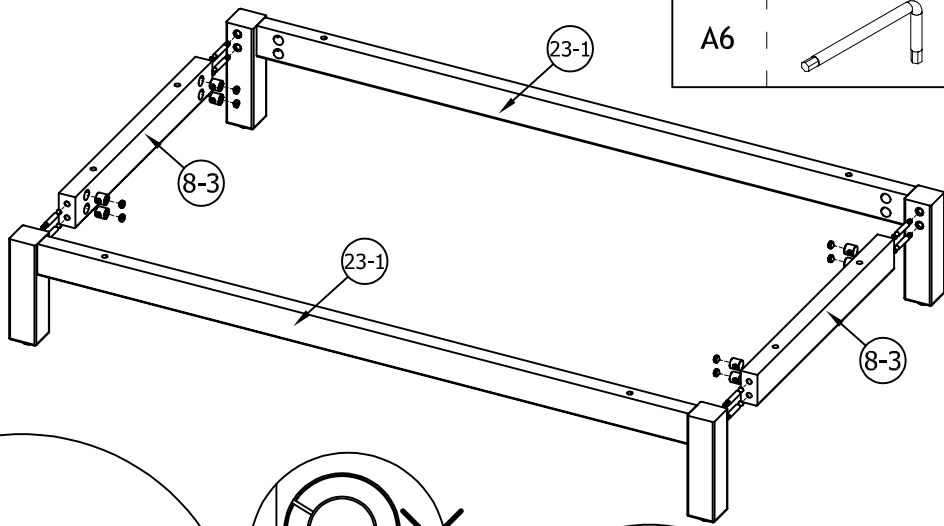

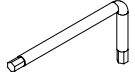
A6		x1 4 mm
----	---	------------

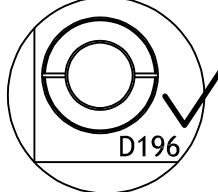
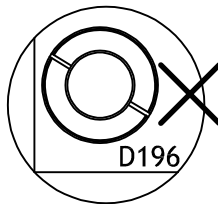
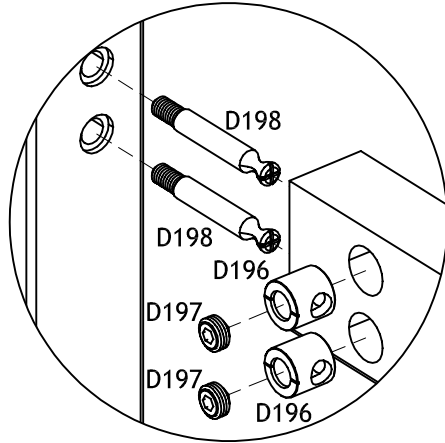

8x

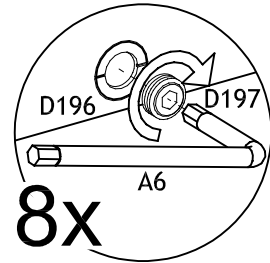
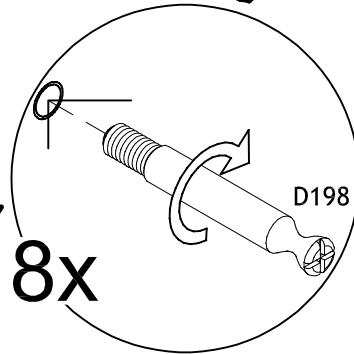

8x

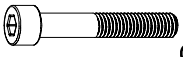
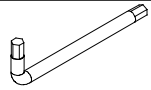
A232		x8 Ø13/M8x50	A172		x1 6 mm
------	---	-----------------	------	---	------------

2.

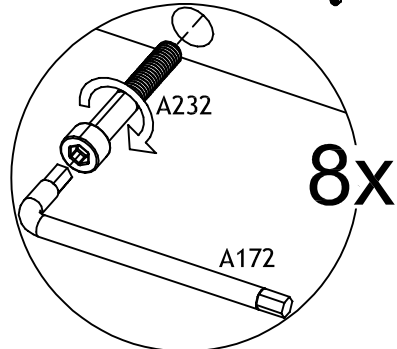
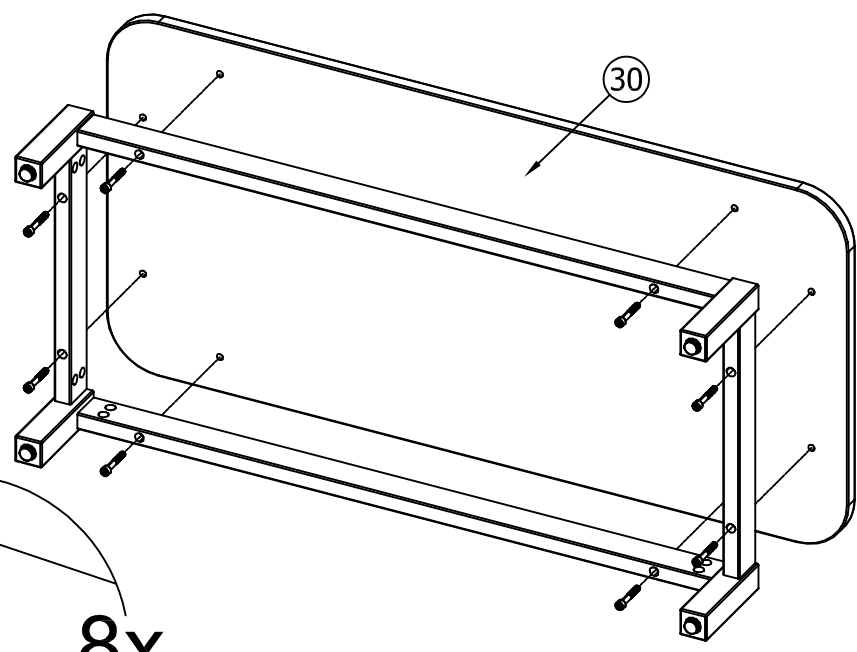

8x

D198 |  x6
Ø7x34 M6 SISO

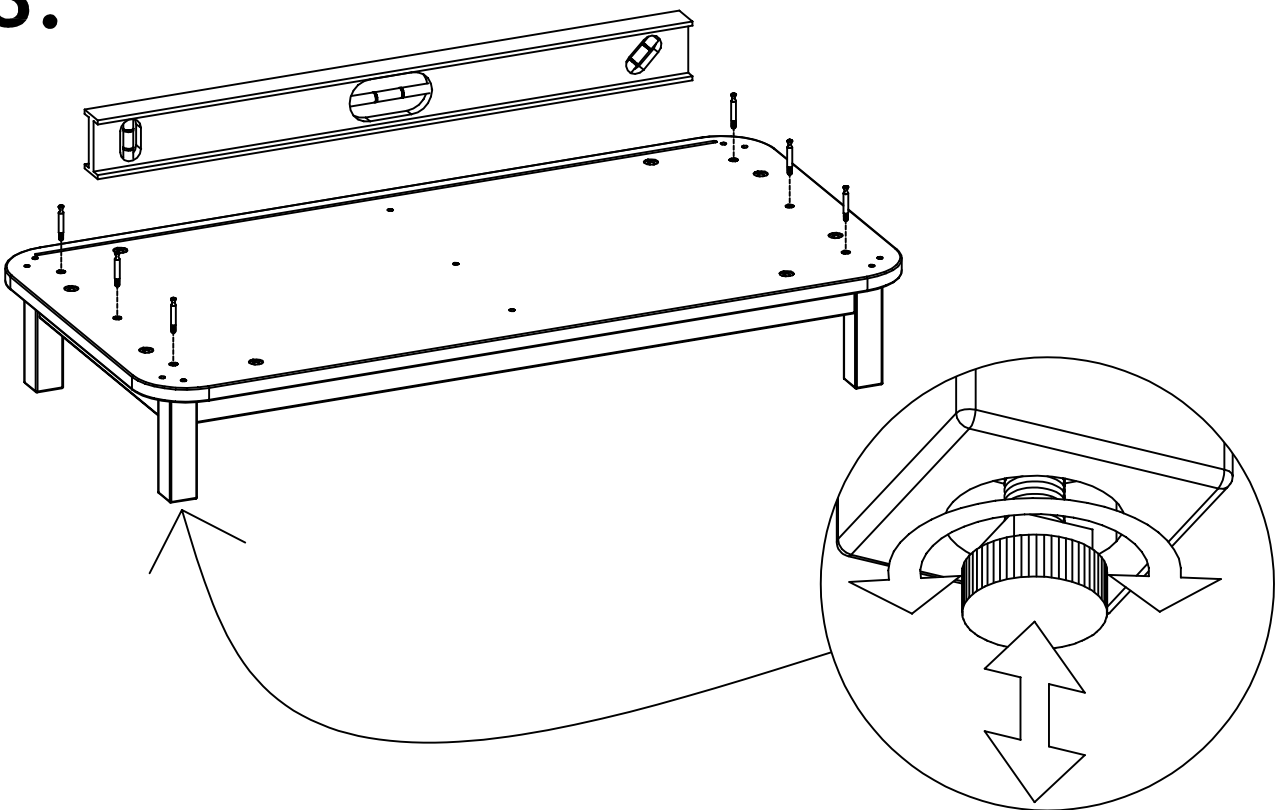

3.



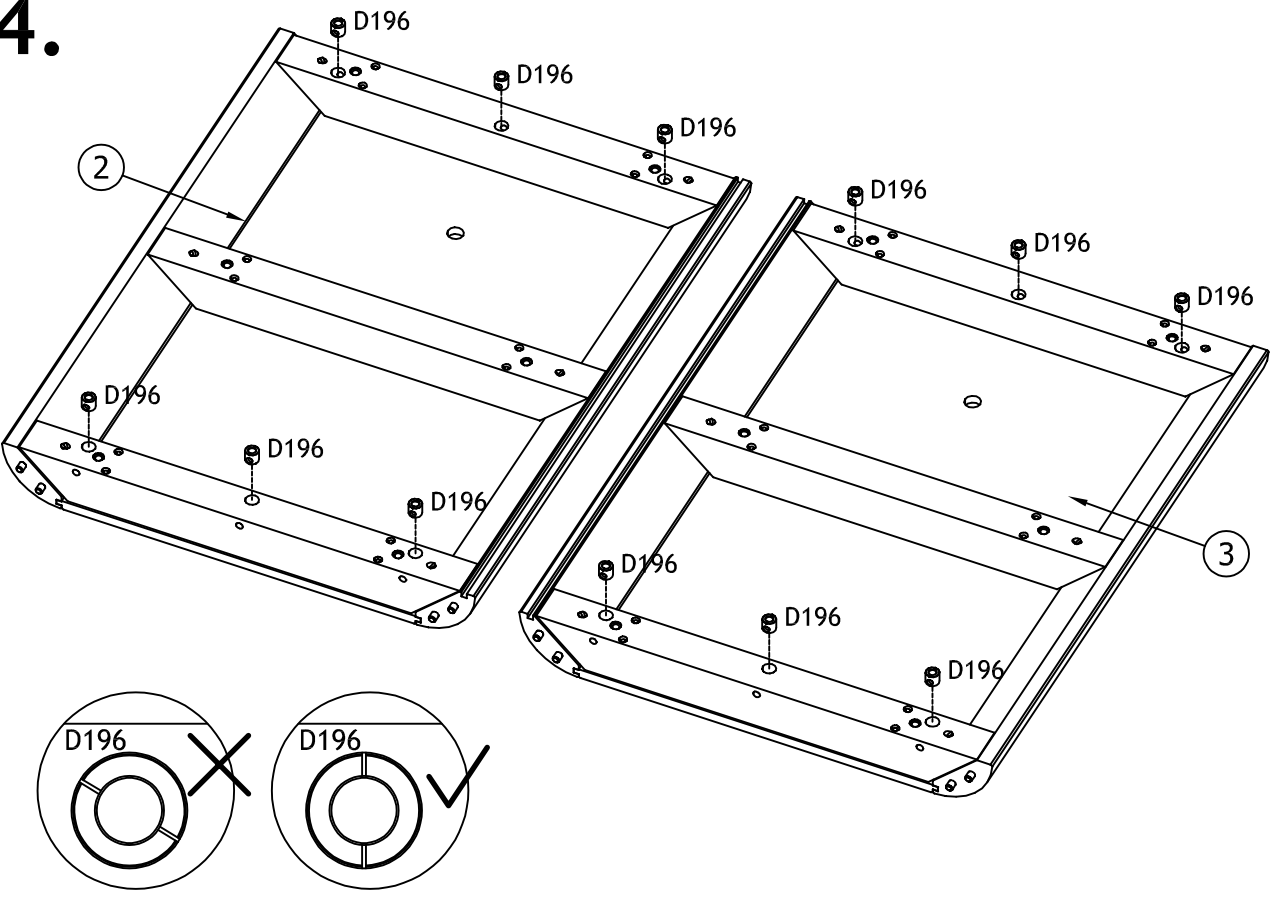

D196 |  x12
Ø15x14

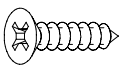
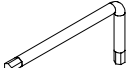
4.

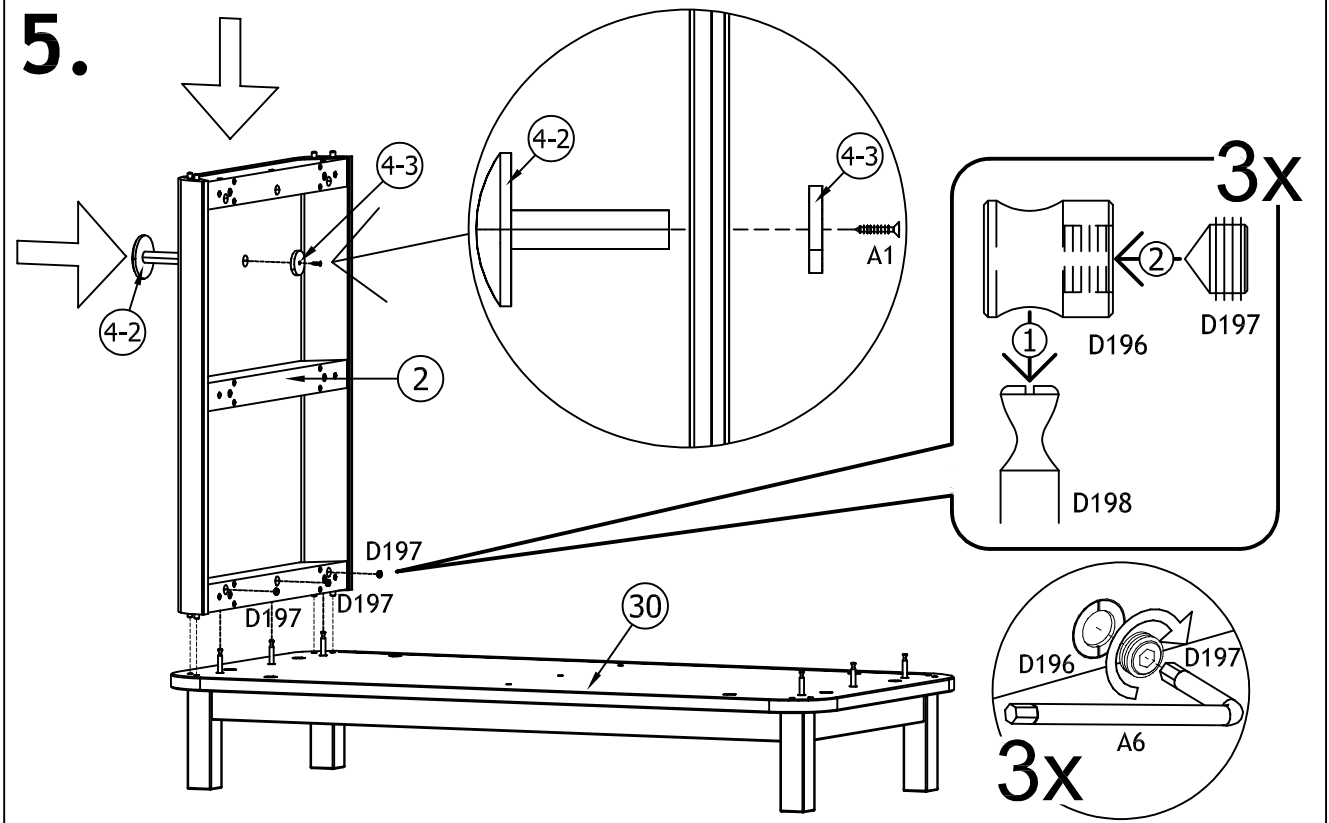

A1	 x1 Ø3,5x15	A6	 x1 4 mm	D197	 x3 M10x7,5
----	---	----	--	------	---

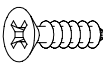

E87	 x2 485 mm	A25	 x8 Ø7,8/6,2x10,5	A136	 x8 Ø4x12
-----	--	-----	---	------	---

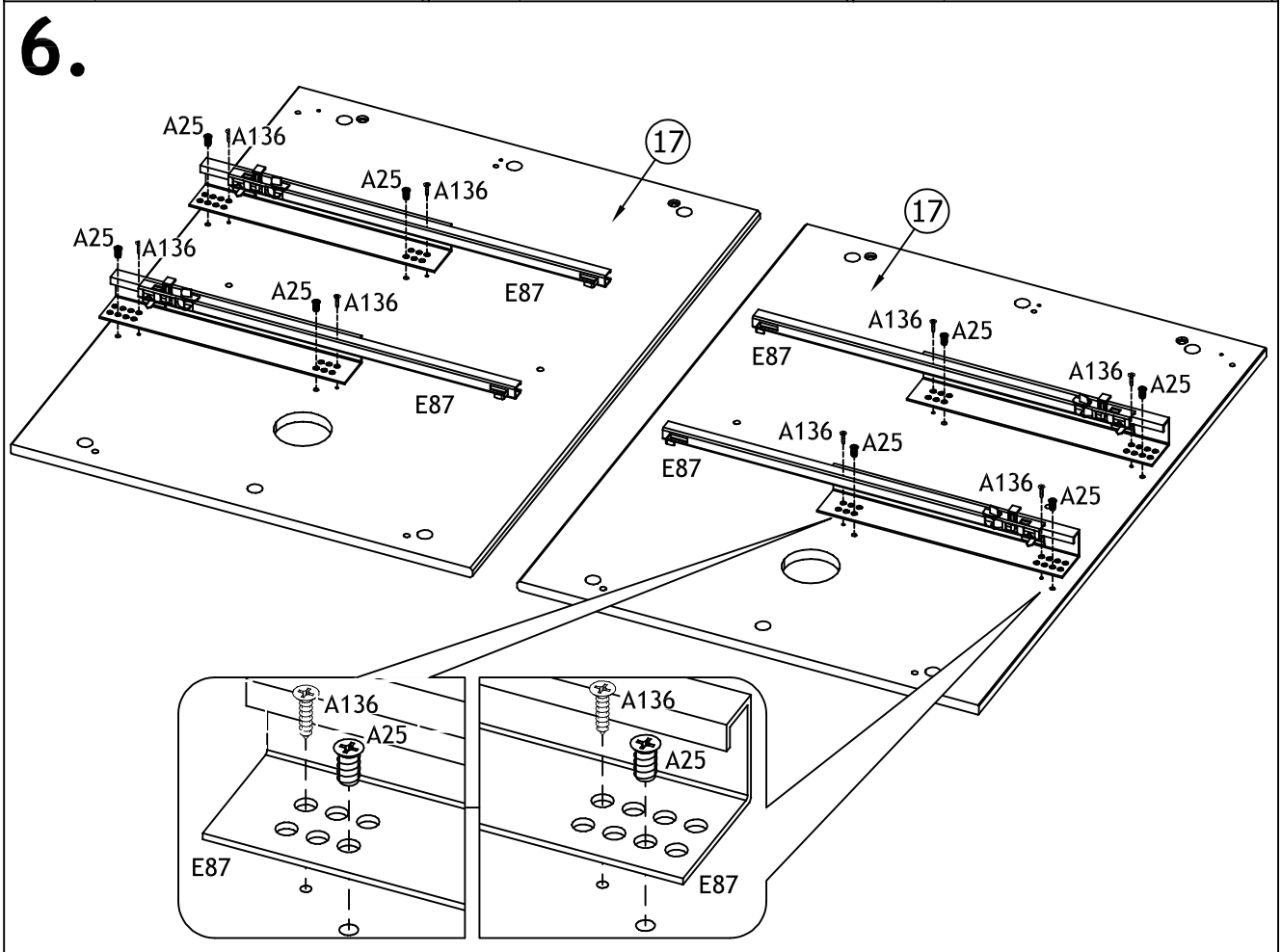

7.

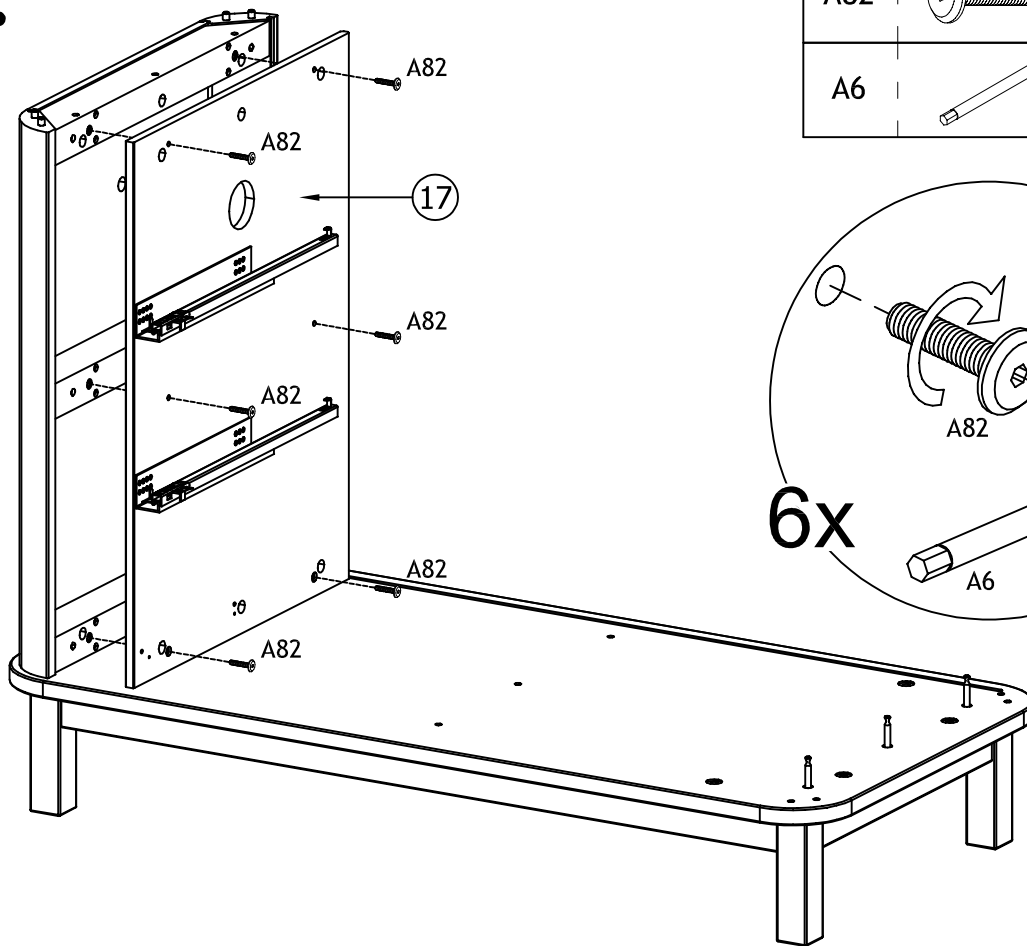

A82		x6
		M6x30
A6		x1
		4 mm

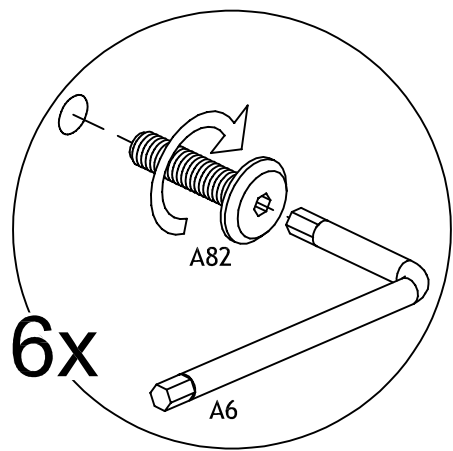

E87		x1	485 mm	A25		x2	Ø7,8/6,2x10,5	A136		x2	Ø4x12
-----	--	----	--------	-----	--	----	---------------	------	--	----	-------

8.

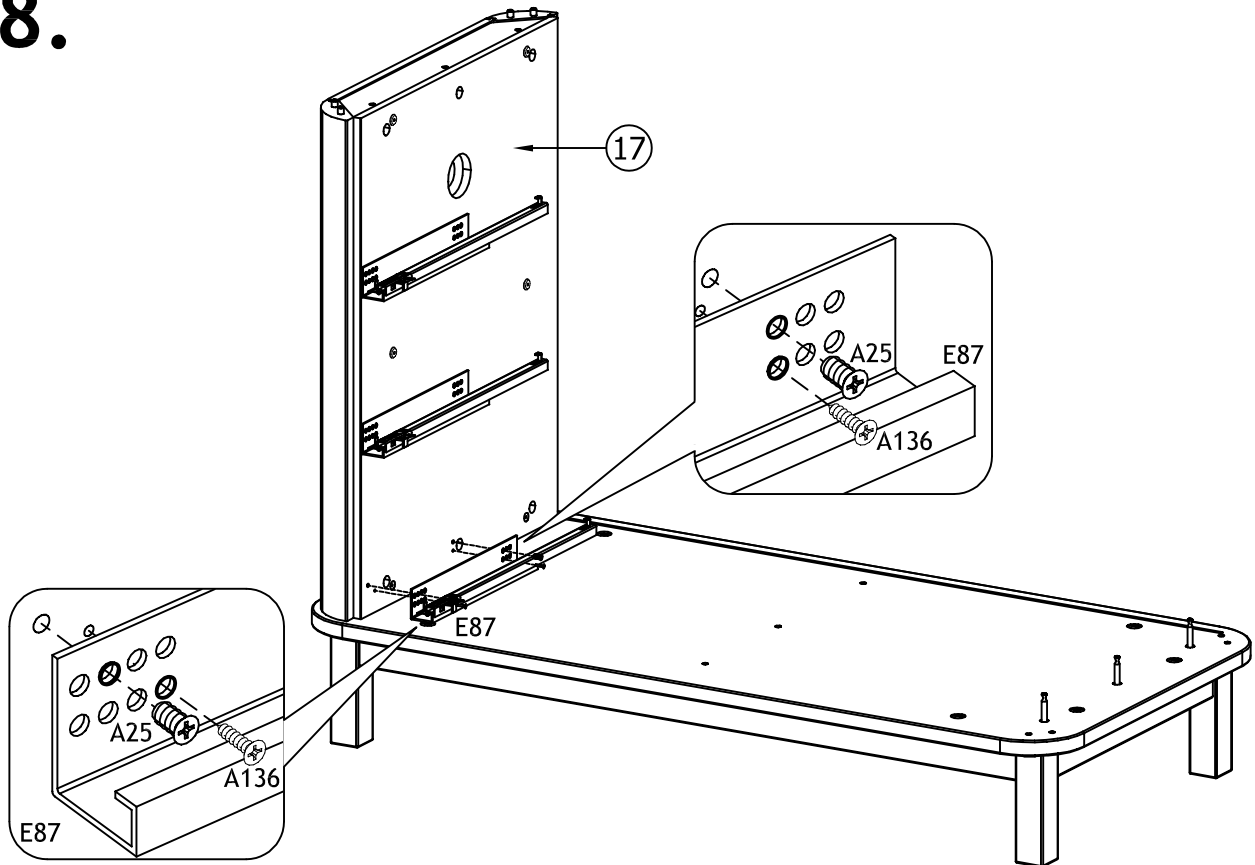

9.

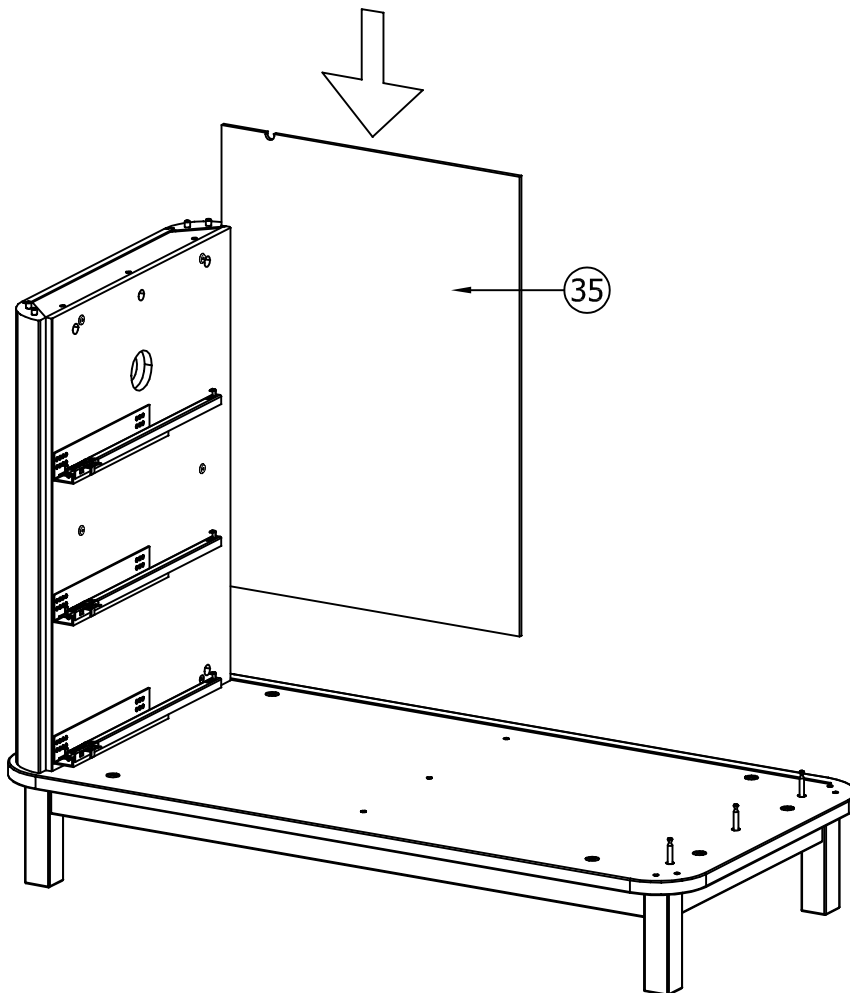

E87

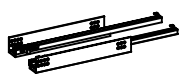

x2

485 mm

10.

33

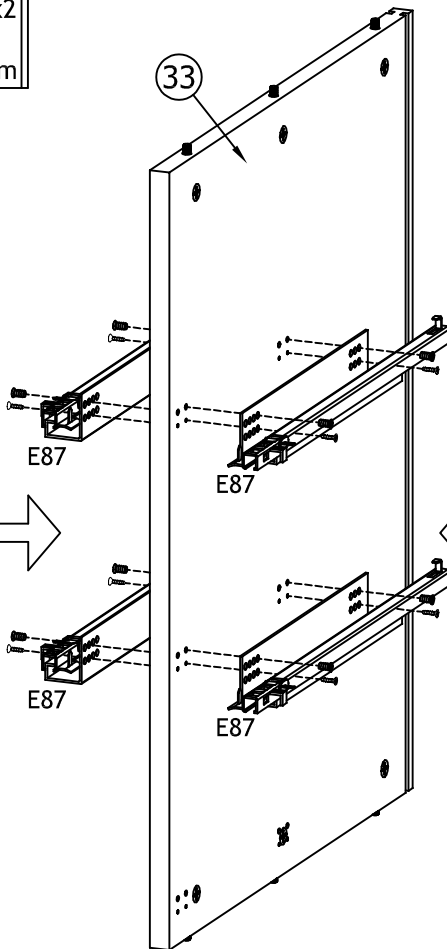

A136

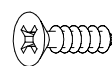

x8

Ø4x12

A25



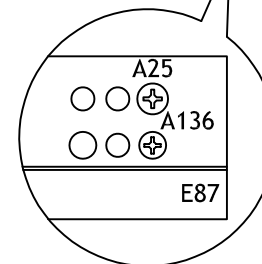
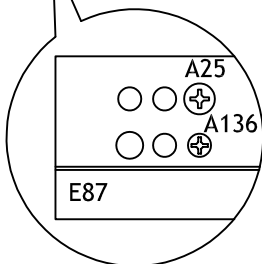
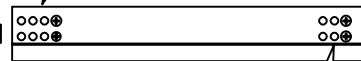
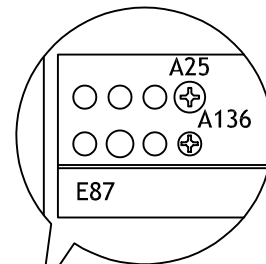
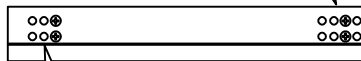
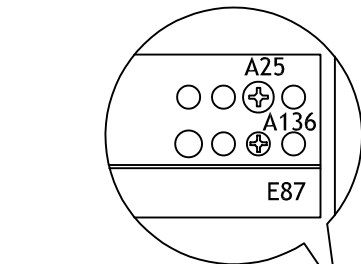

x8

Ø7,8/6,2x10,5

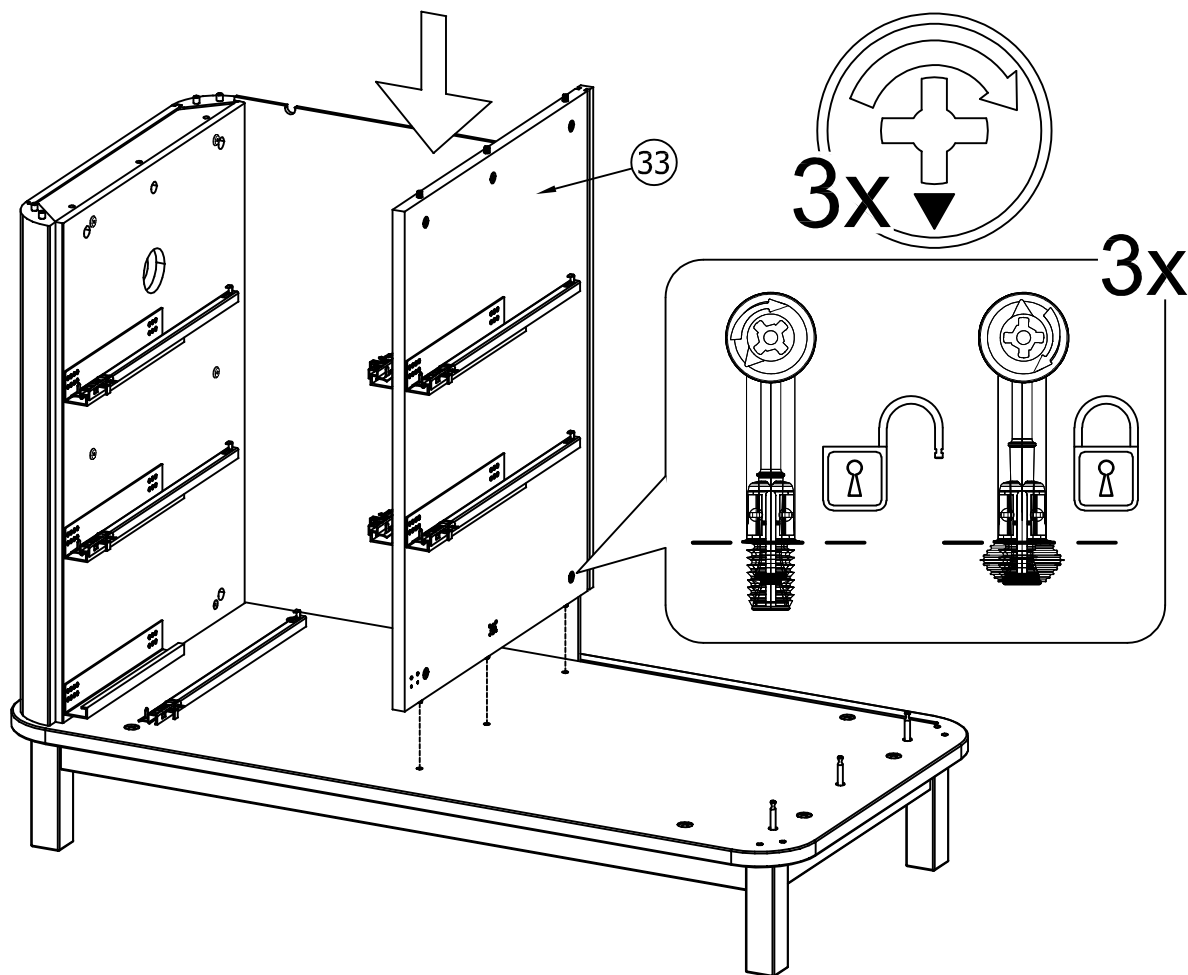

11.

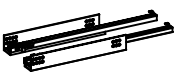

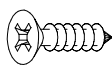

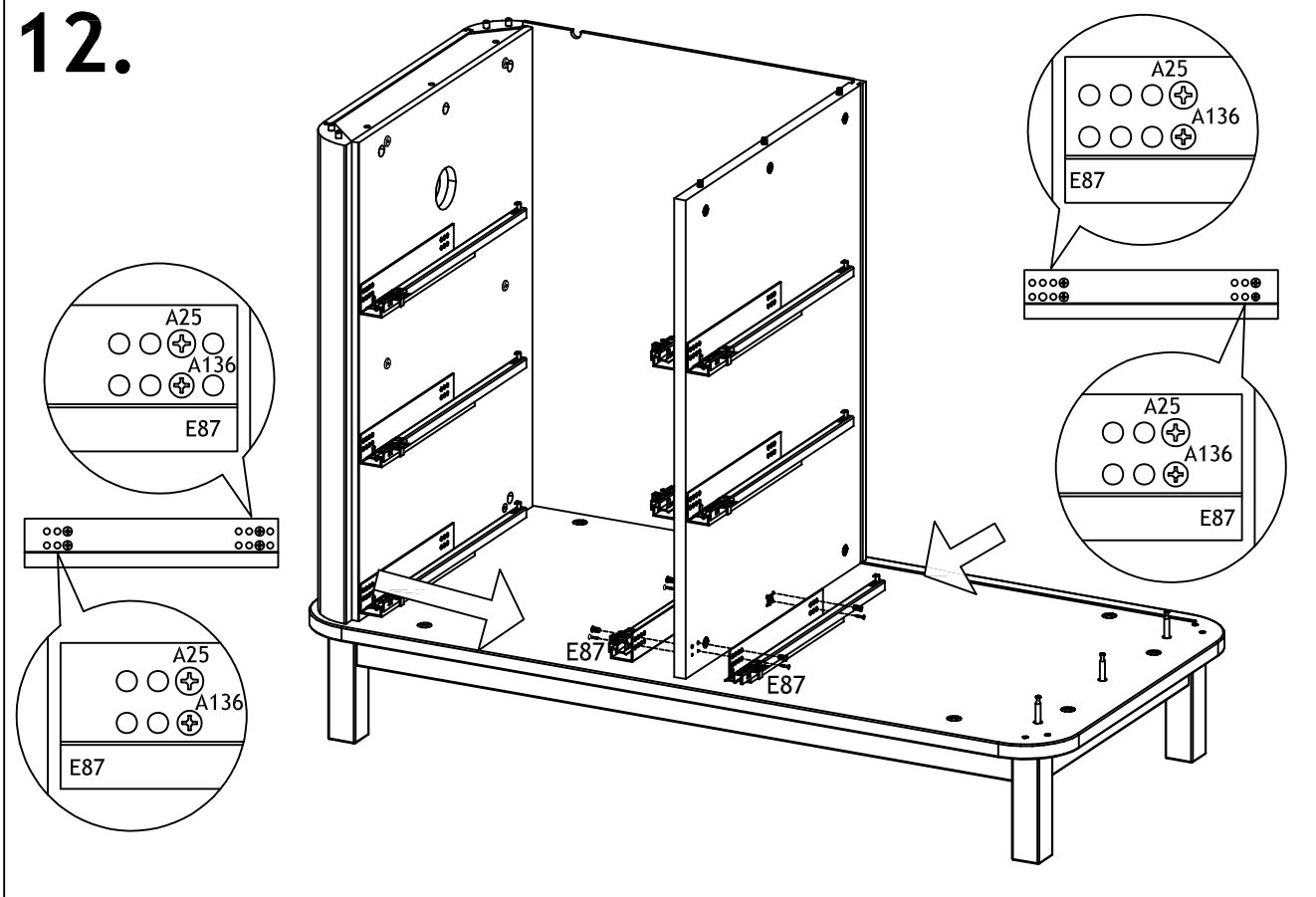

E87	 x1 485 mm	A25	 x4 Ø7,8/6,2x10,5	A136	 x4 Ø4x12
-----	--	-----	---	------	---

12.

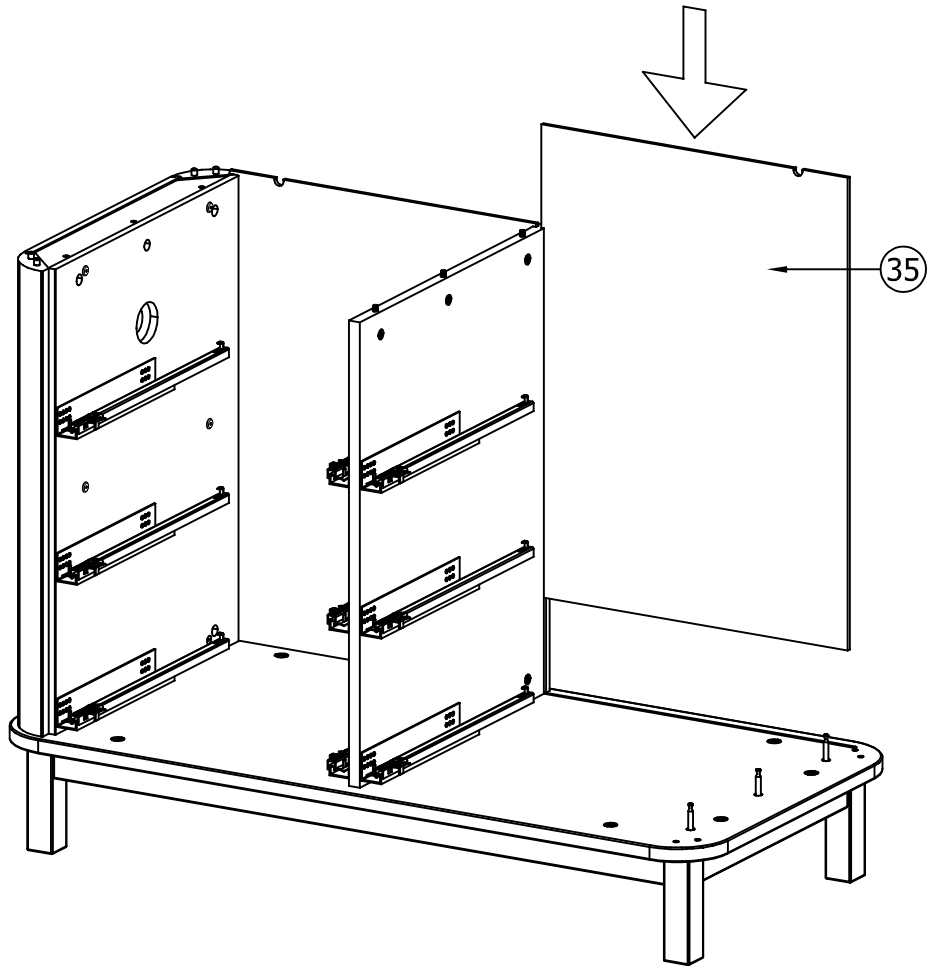

13.



A1		x1	A6		x1	D197		x3
		Ø3,5x15			4 mm			M10x7,5

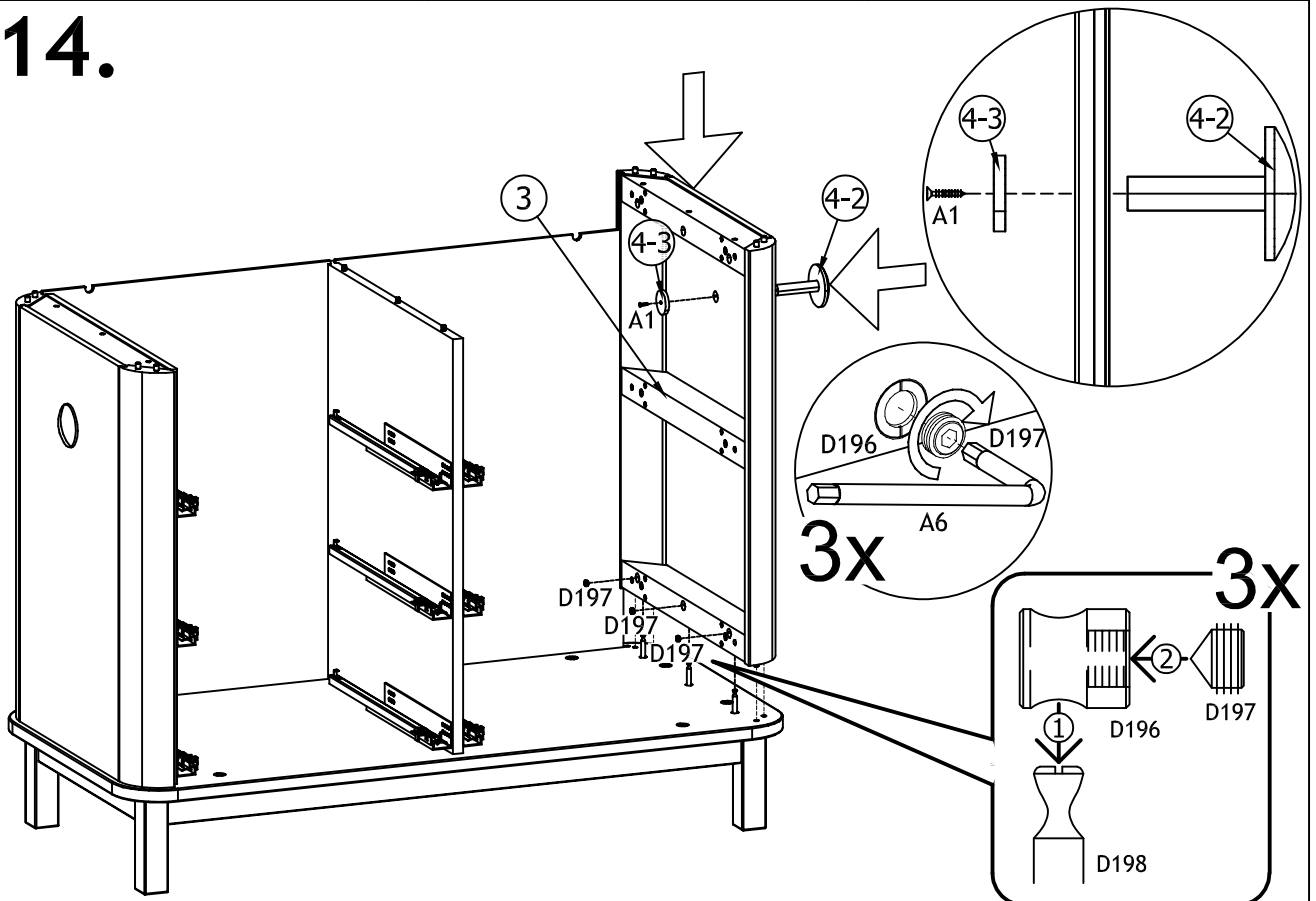

14.

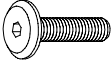
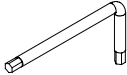

15.

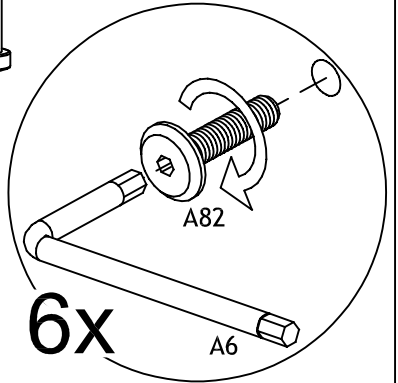
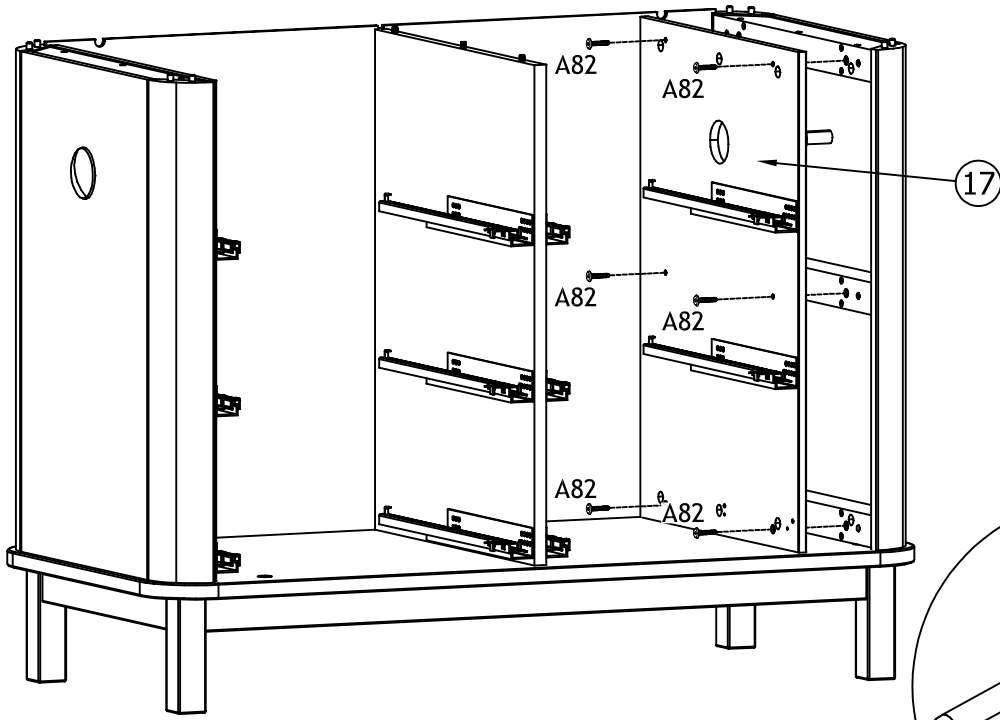
A82		x6 M6x30	A6		x1 4 mm
-----	---	-------------	----	---	------------

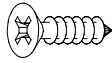

E87		x1 485 mm	A25		x2 Ø7,8/6,2x10,5	A136		x2 Ø4x12
-----	---	--------------	-----	---	---------------------	------	---	-------------

16.

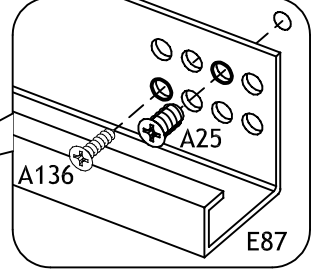
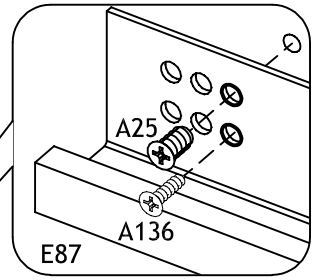
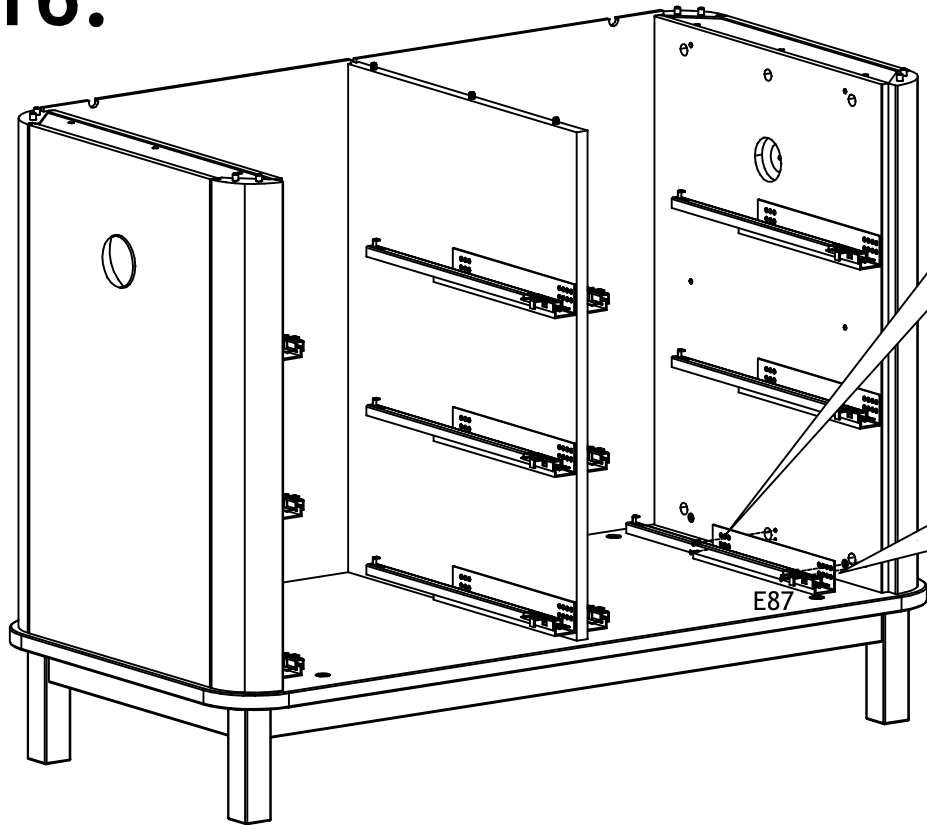

17.

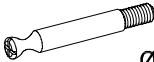
D198		x6
Ø7x34 M6 SISO		

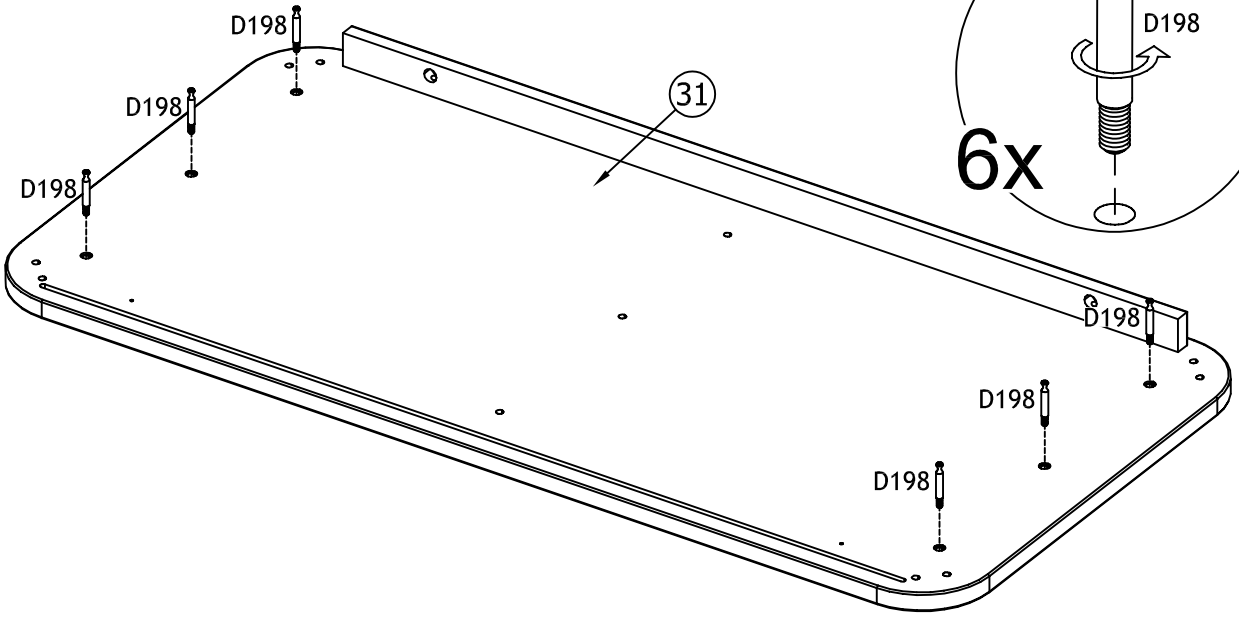

6x

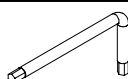
D197		x6
M10x7,5		
A6		x1
4 mm		

18.

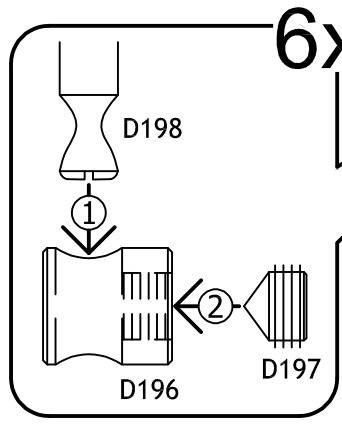
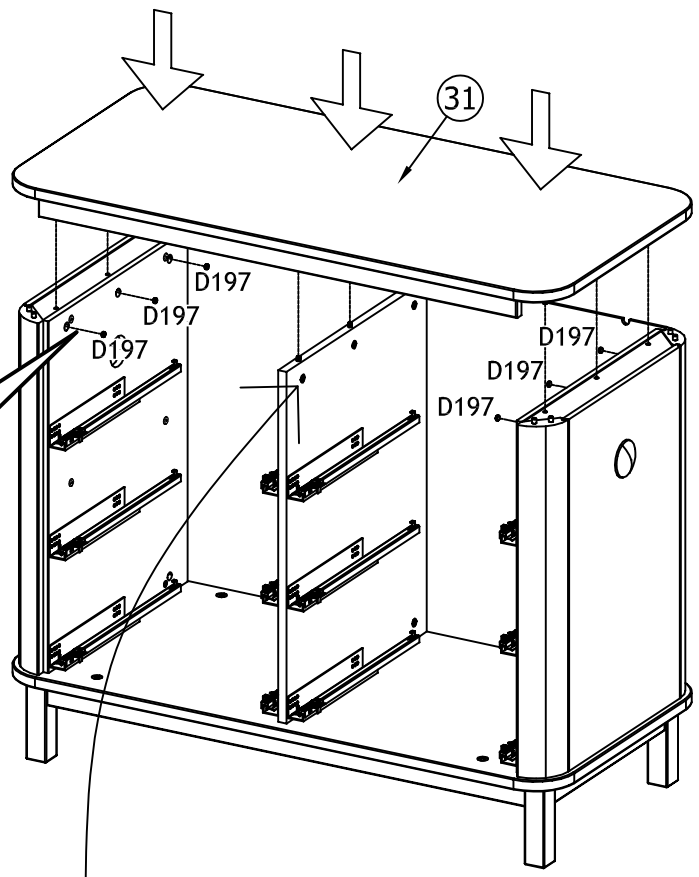

6x

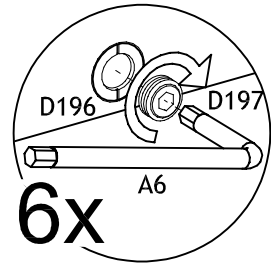

6x

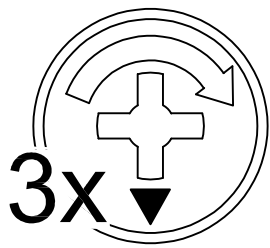

3x

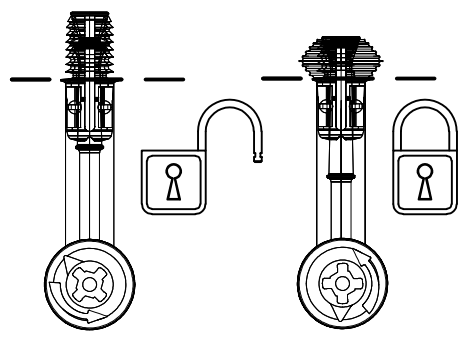

D39

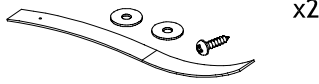

x2

19.

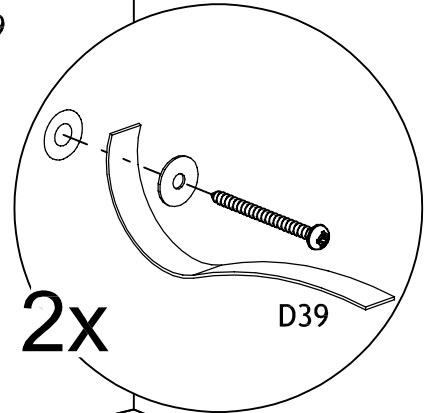
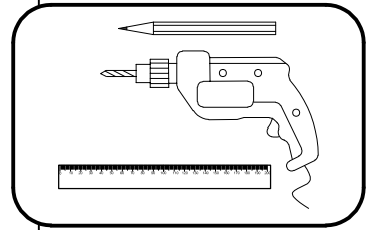
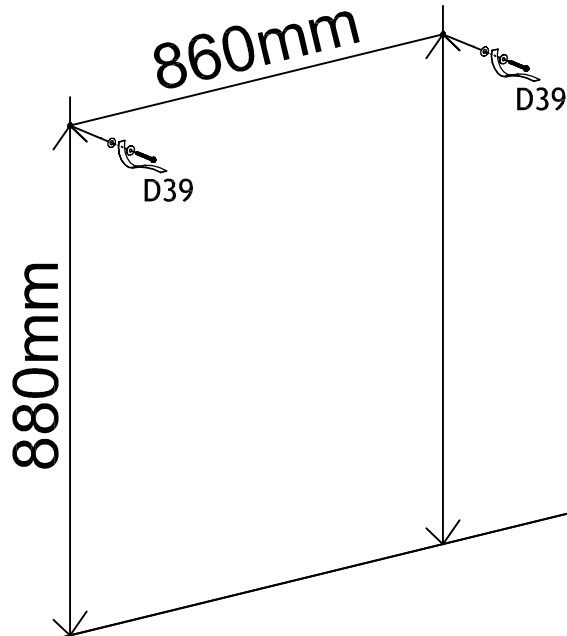

DK: Fastgøres forsvarligt til væggen.

ENG: Secured to the wall.

D: Kippsicherung! Muss an der Wand befestigt und abgesichert werden.

D39

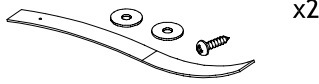

x2

20.

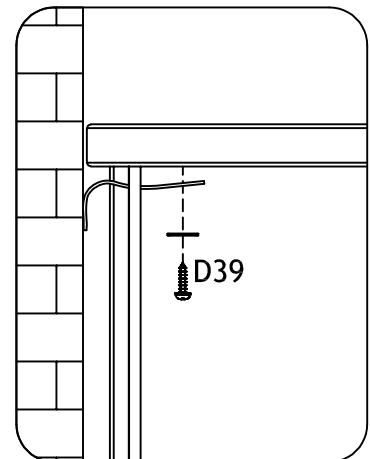
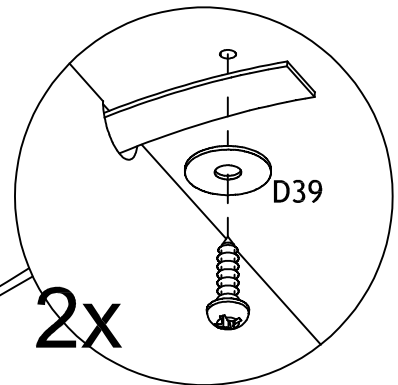
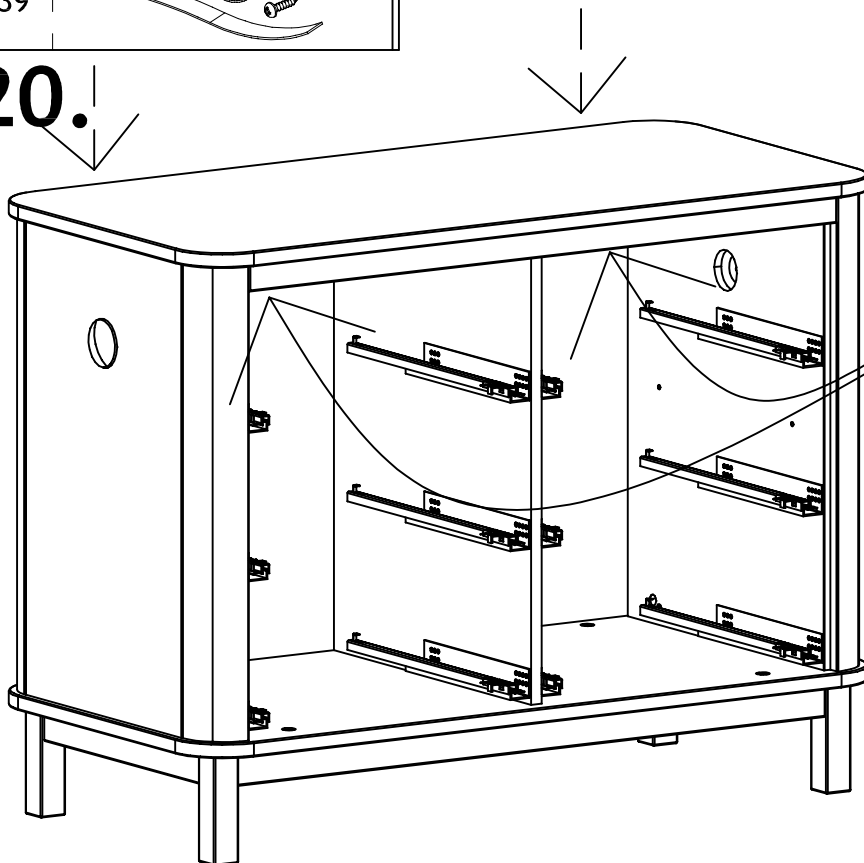

21.

