

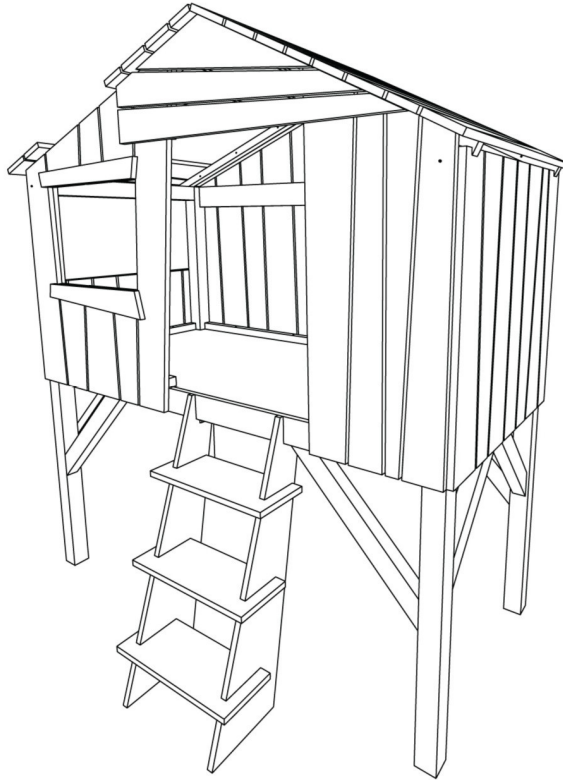

# Lits Cabanes : simple ou superposé Boomhut Bedden : eenvoudig of stapelbed Treehouse Beds : single or bunk bed

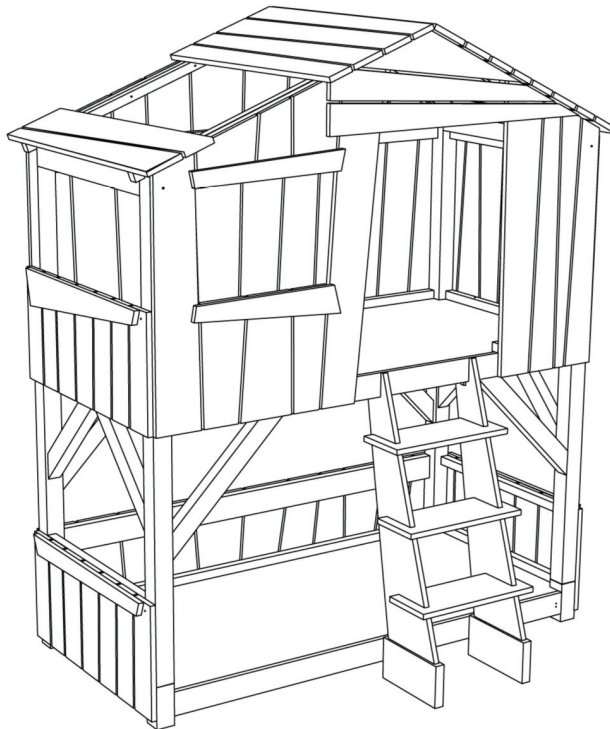

Réf. CAB LIT 90F MDF  
CAB LIT 90F TILL MASS



Réf. CAB LIT SUP 90F MDF  
CAB LIT SUP 90F TILL MASS

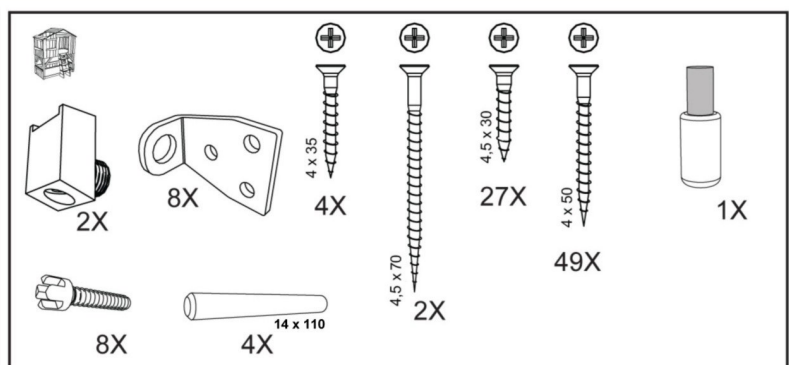
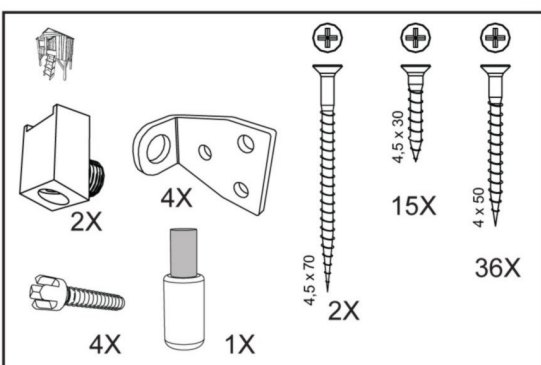
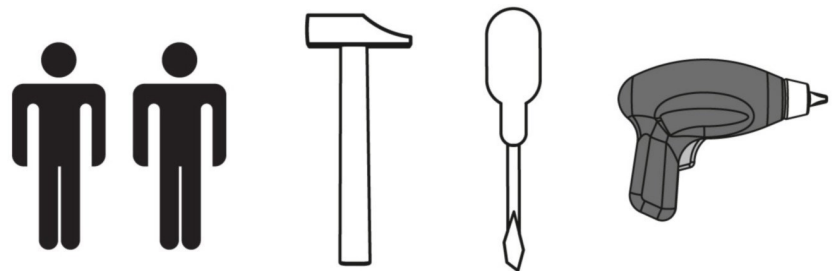
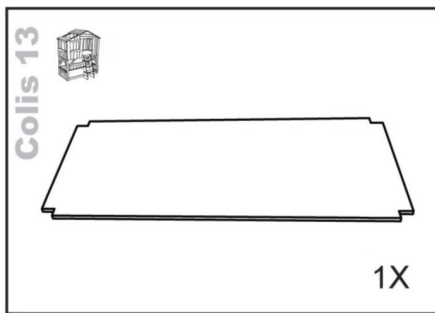
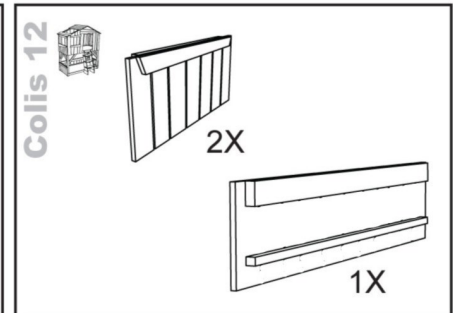
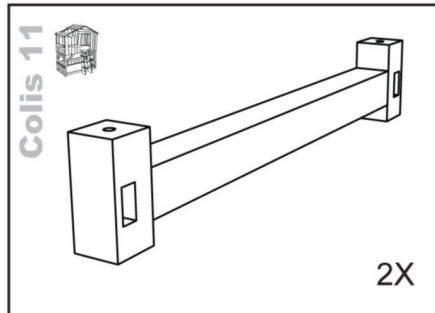
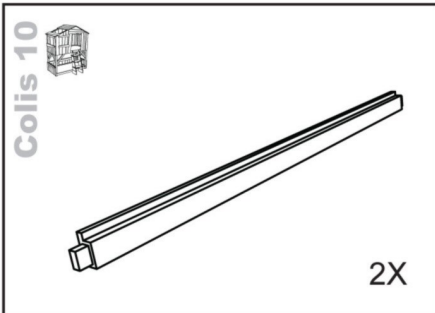
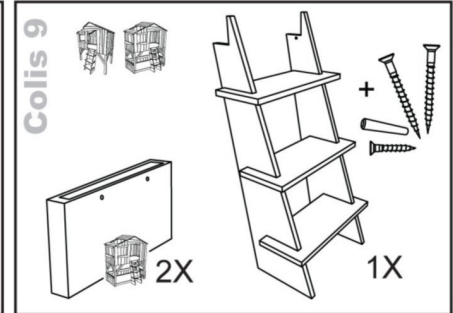
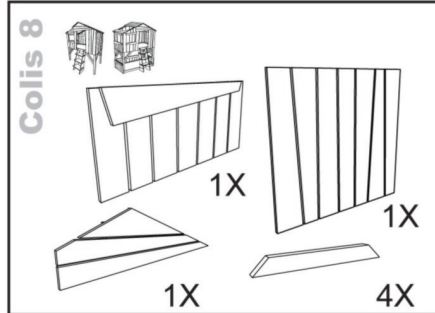
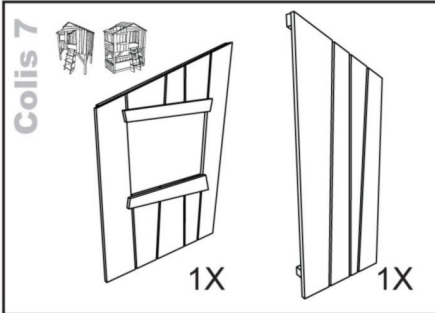
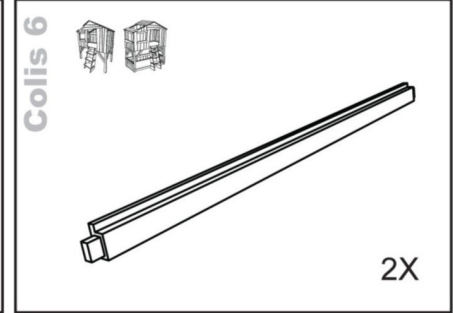
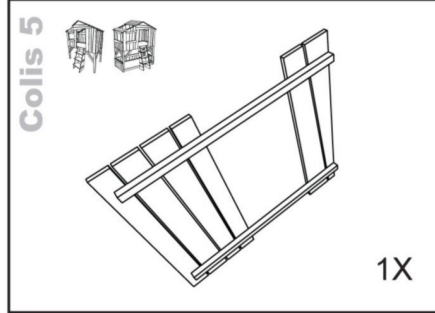
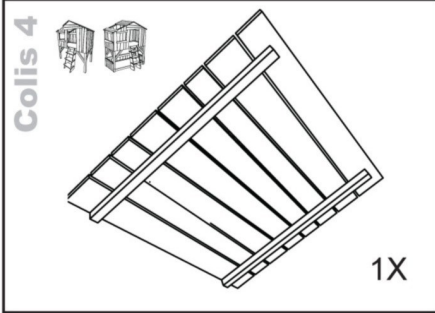
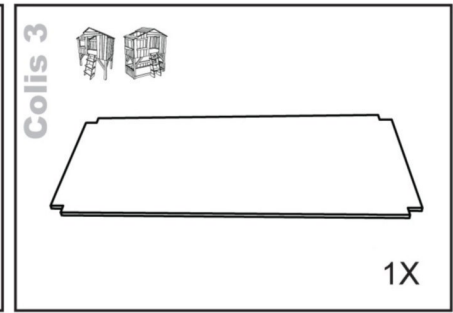
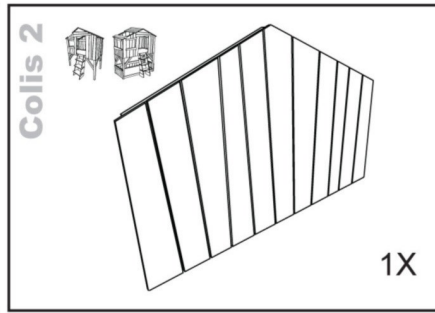
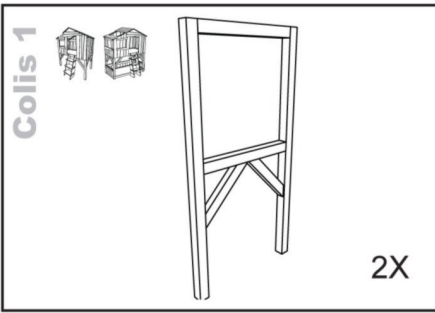



MATHYBYBOLS



1

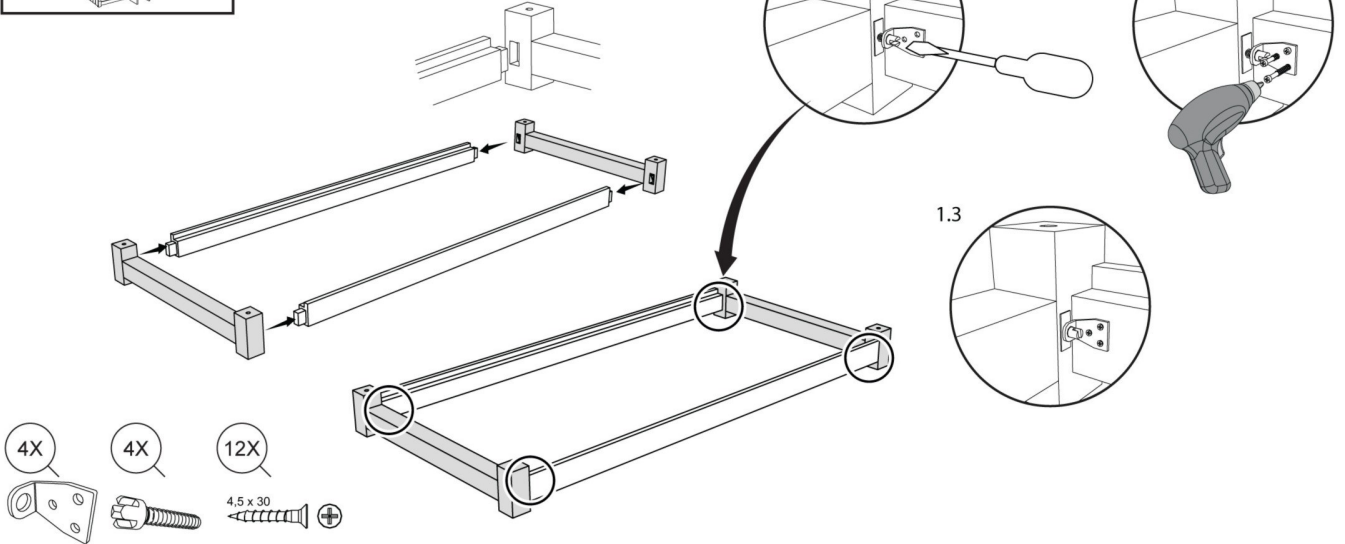

2

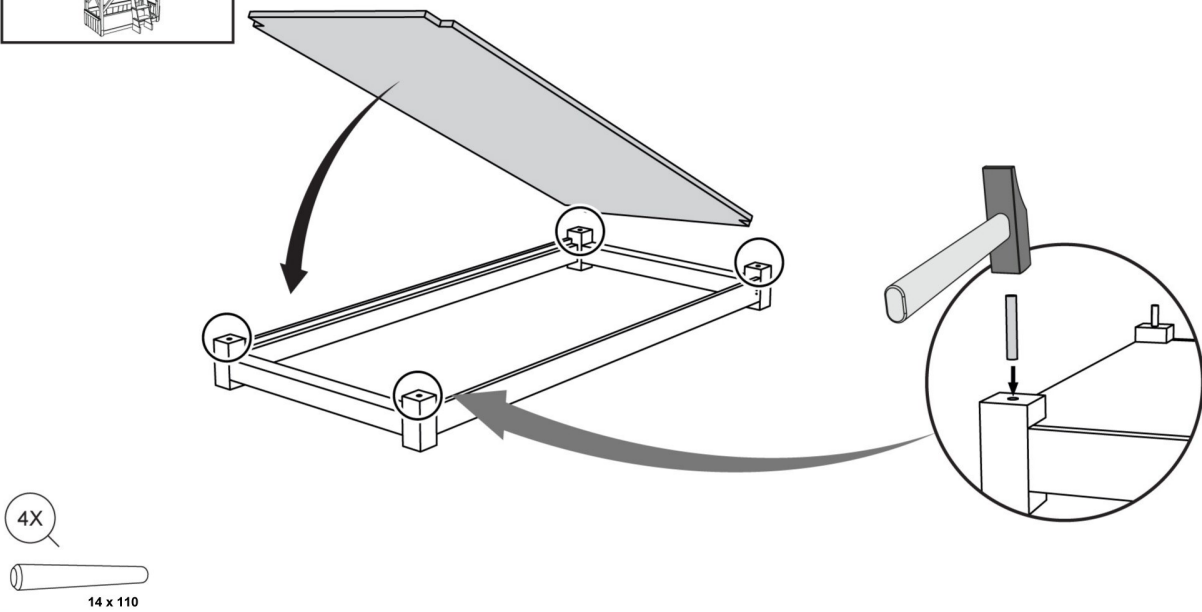

3

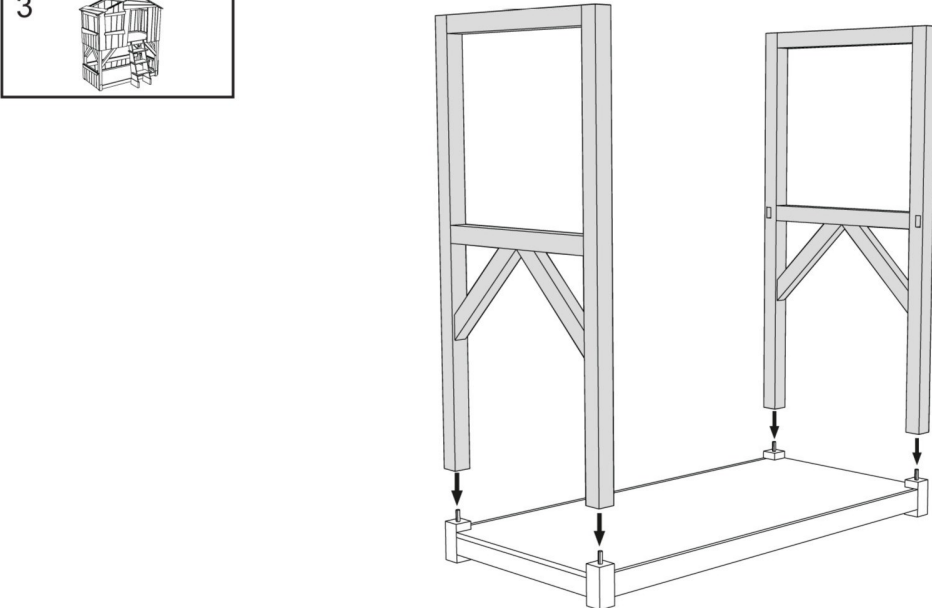

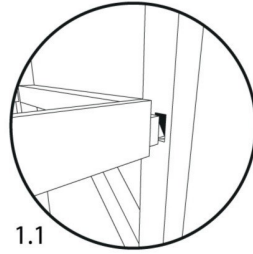
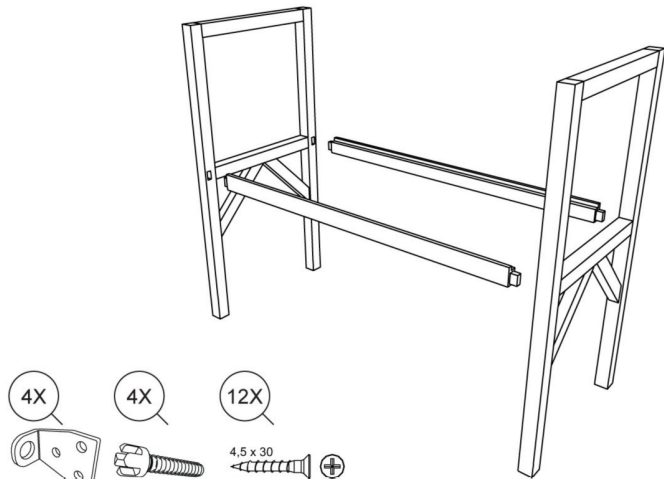
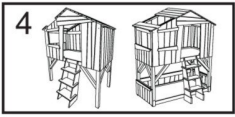

1.1

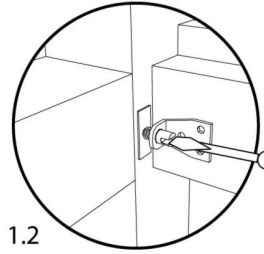

1.2

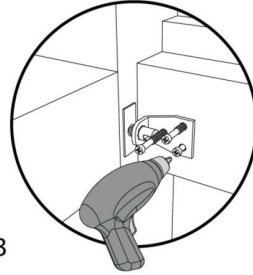

1.3

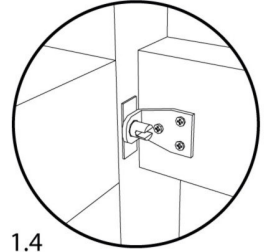

1.4

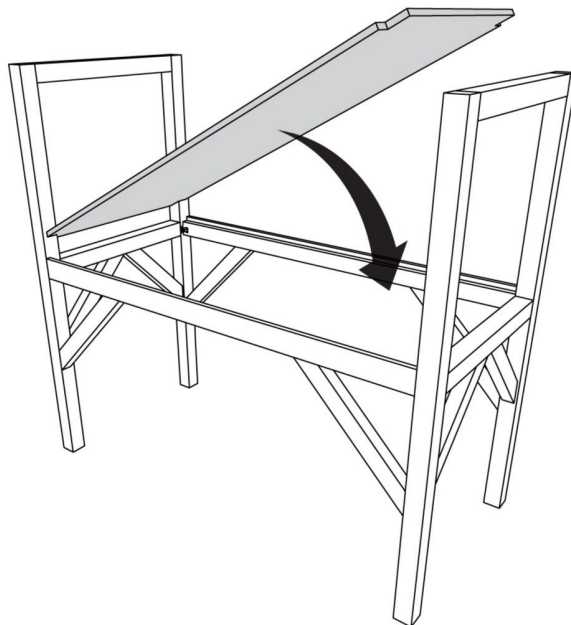
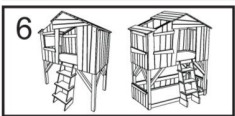
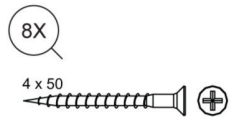
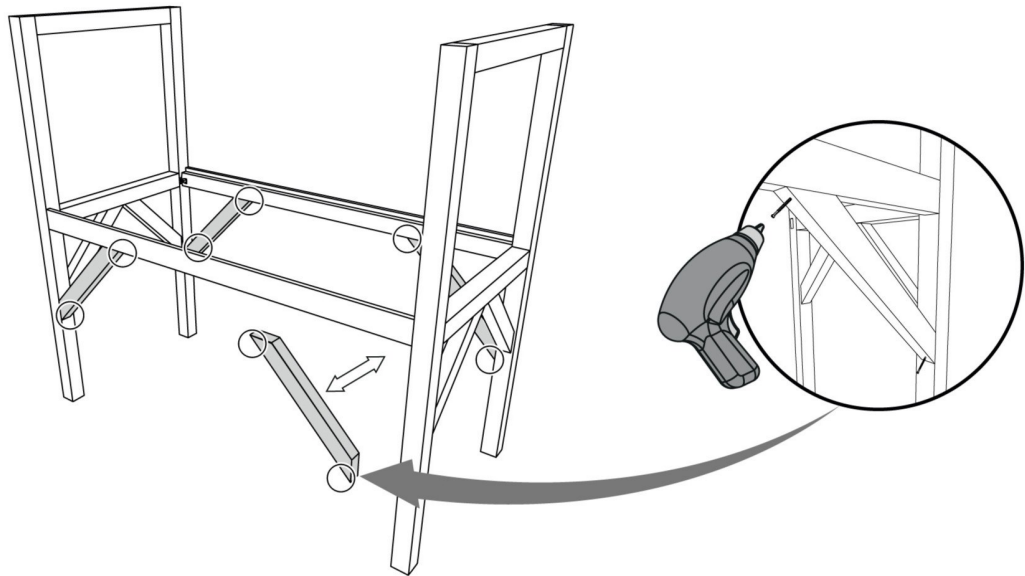
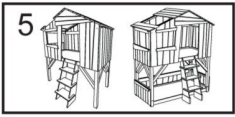
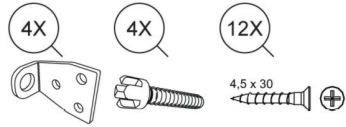

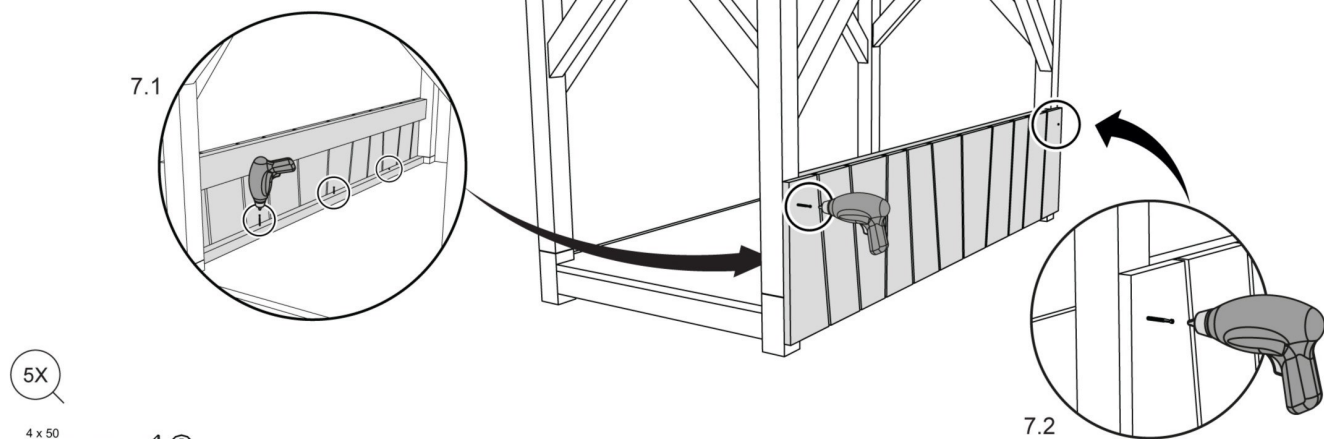

5X

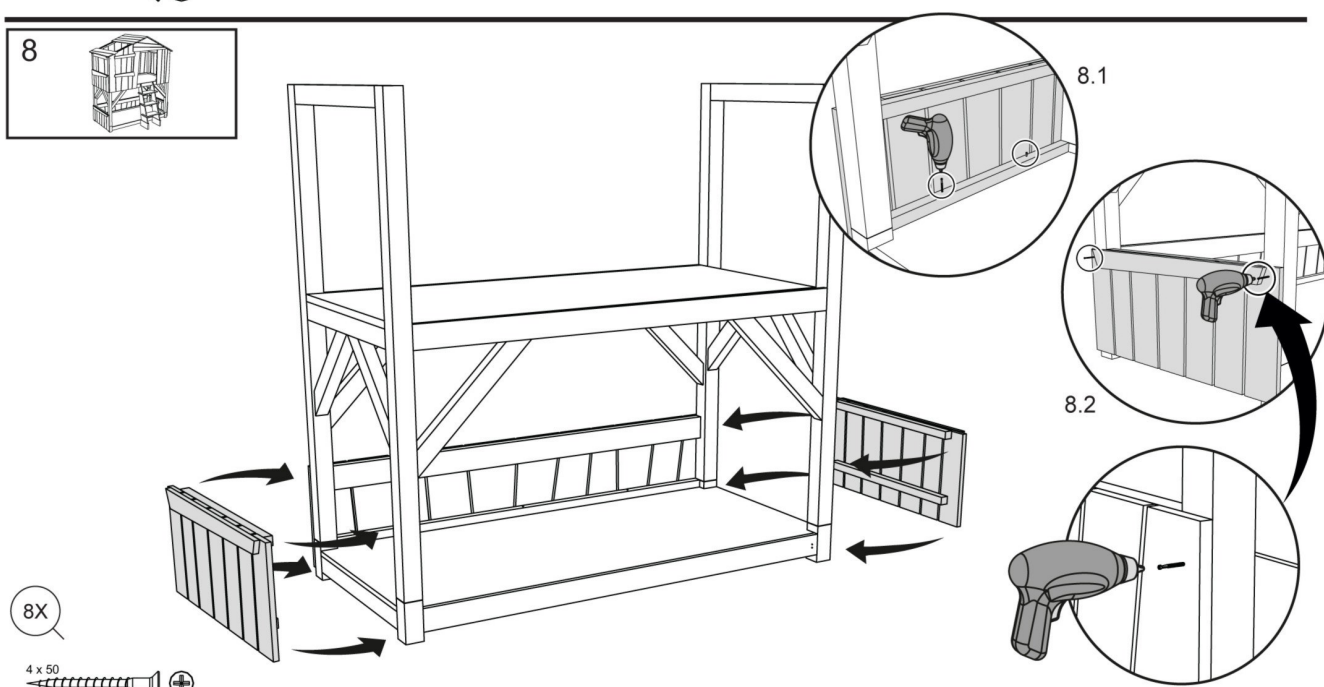
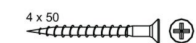

8X

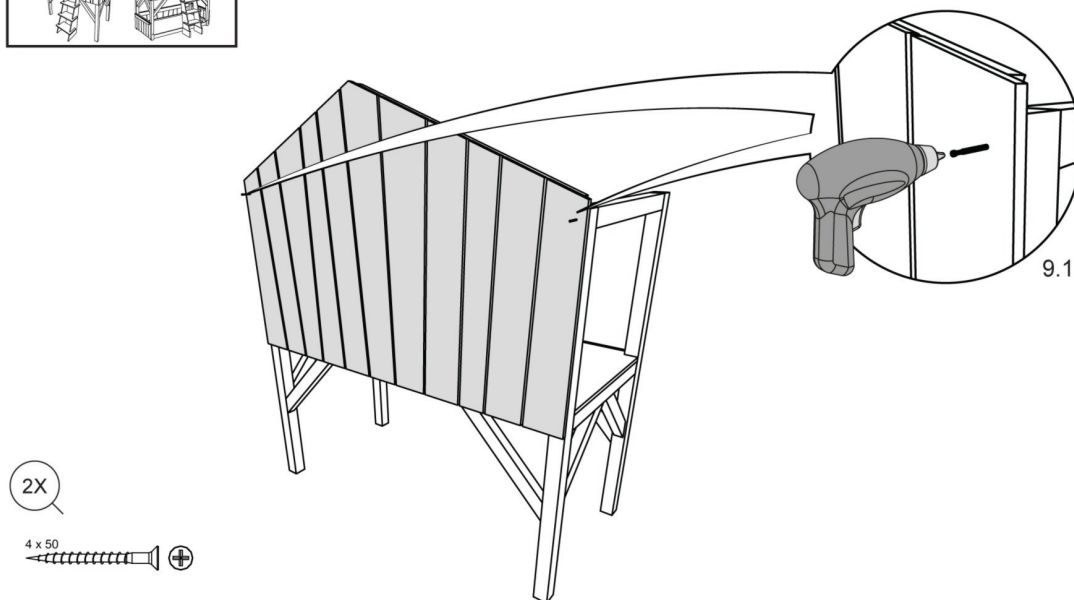

2X

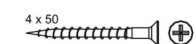

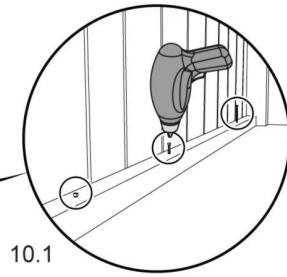
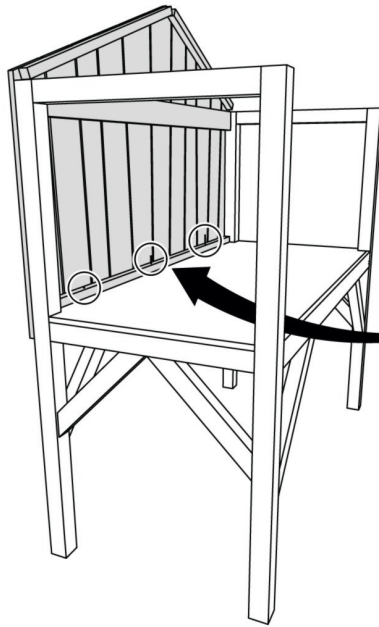
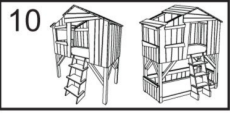

10.1

3X

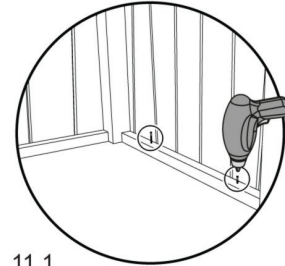
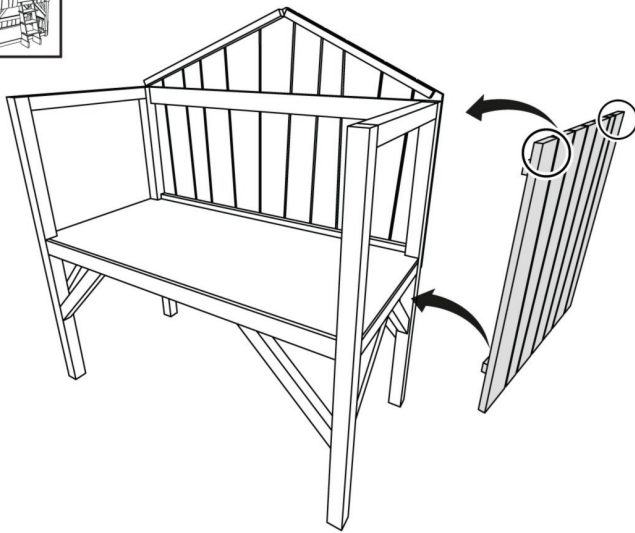
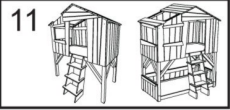
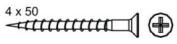

11.1

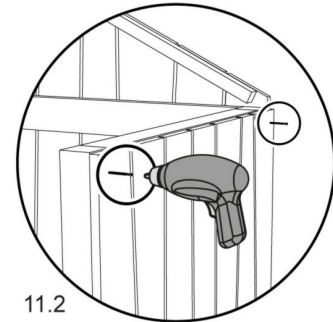

11.2

4X

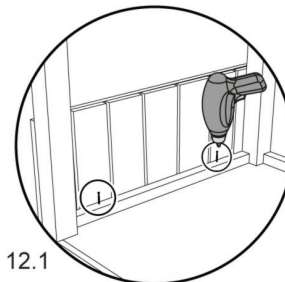
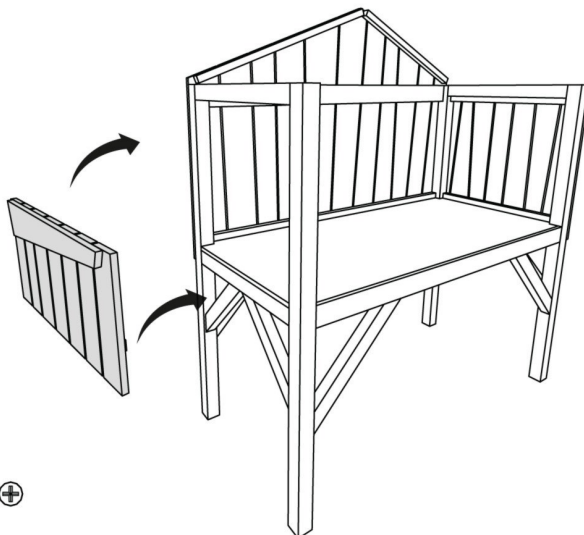
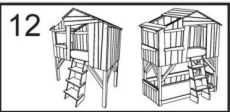
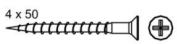

12.1

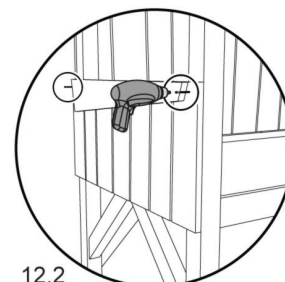

12.2

4X

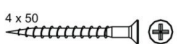

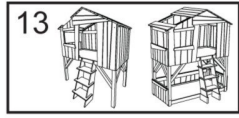

13

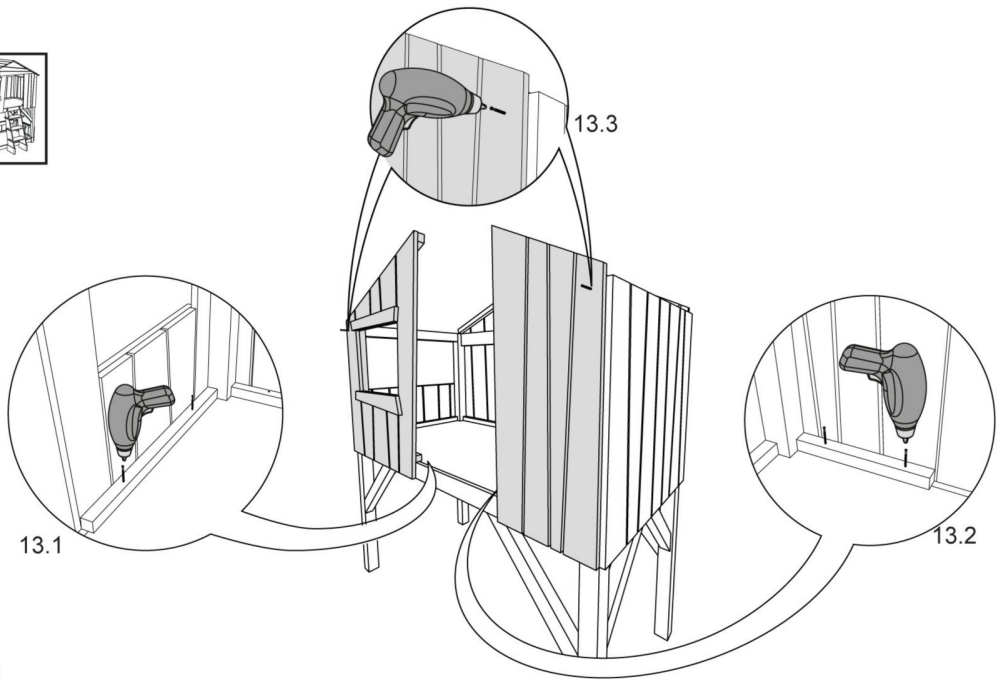

6X

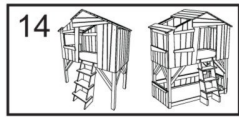
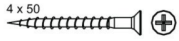

14

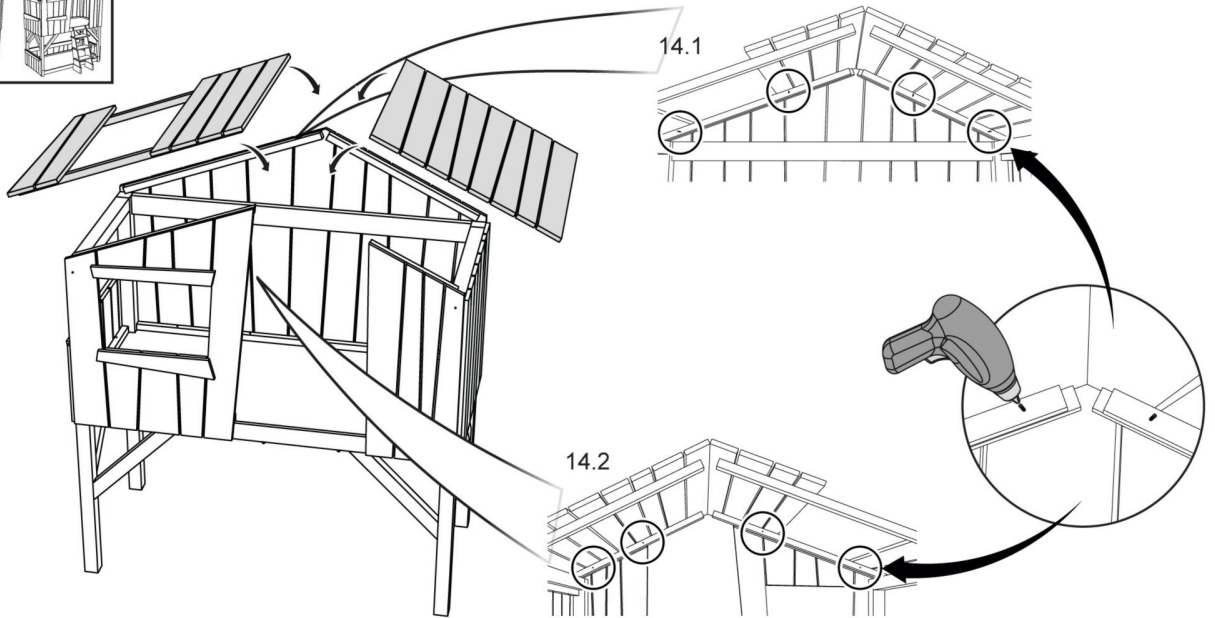

8X

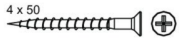

15

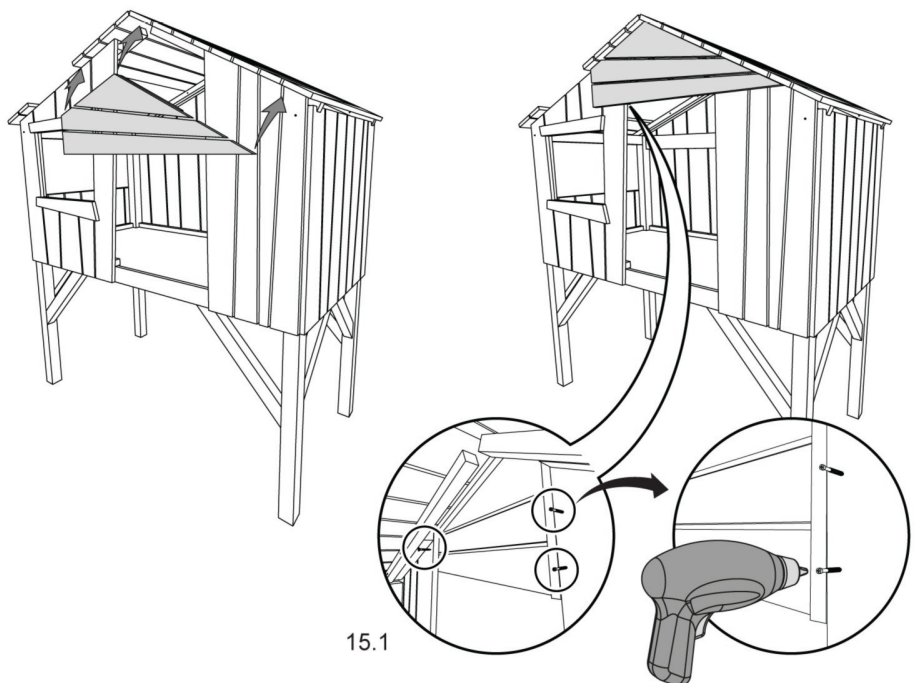

3X



15.1

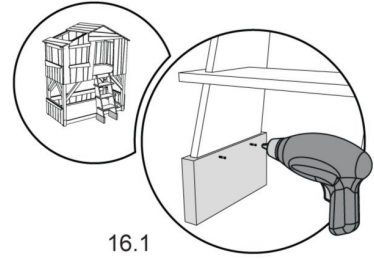
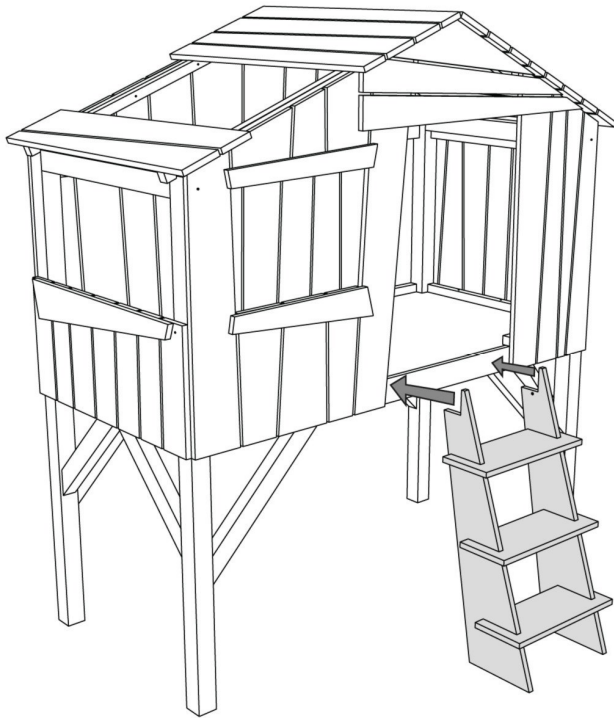
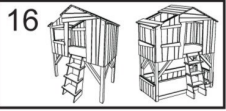

16.1

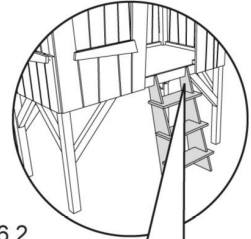

16.2

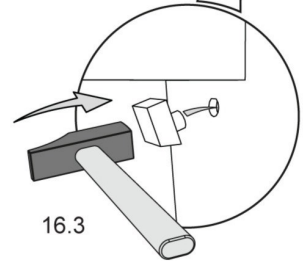

16.3

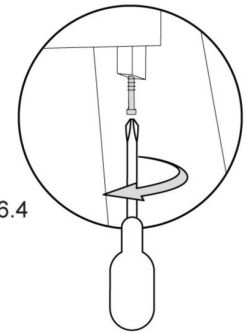

16.4

(16.1)

4X



(16.3)

2X



(16.4)

2X

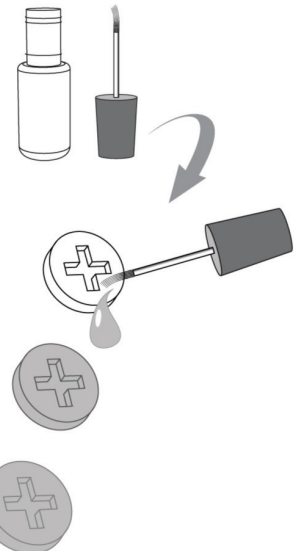
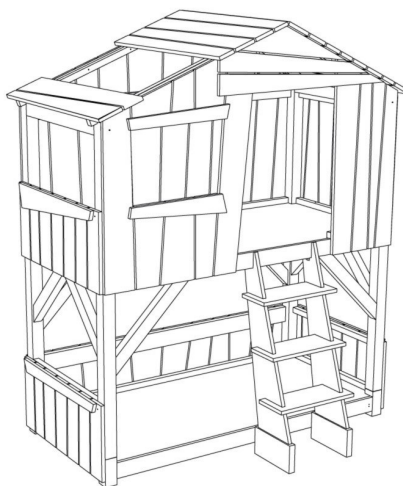
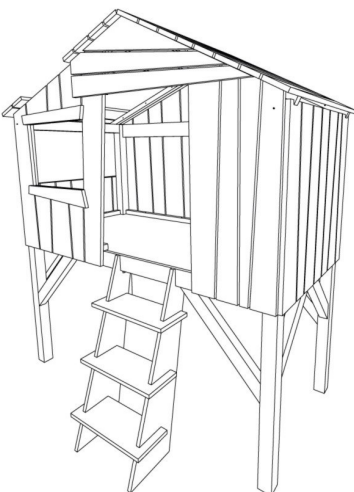
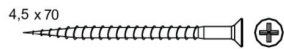

18





**FR: IMPORTANT - A CONSERVER POUR CONSULTATION ULTERIEURE - A LIRE SOIGNEUSEMENT.**

Le lit supérieur ne convient pas pour les enfants de moins de six ans en raison du risque de blessure due aux chutes du lit.

Les enfants peuvent se coincer entre le lit et le mur. Pour réduire le risque de blessure grave, la distance entre la barrière de sécurité supérieure et la paroi doit être inférieure à 75 mm ou plus de 230mm.

Assemblez le lit suivant les instructions décrites ci-dessous. Lisez attentivement les instructions de montage de l'échelle. Ne modifiez jamais le design et le montage de ce lit.

Avant la mise en service du lit, contrôlez si toutes les pièces détachées sont en bon état, sont bien serrées et ne présentent pas de bords tranchants auxquels l'enfant pourrait se blesser ou rester accroché par ses vêtements (ou cordelettes, collier, ruban de la tétine), ce qui comprend un risque de pendaison. Contrôlez tous les points de jonction.

Contrôlez régulièrement le lit pour détecter les pièces cassées, tordues ou manquantes. Si c'est le cas, mettez le lit hors service.

Remplacement de composants : Utilisez toujours des pièces détachées originales, à obtenir chez le fabricant ou le distributeur.

N'utilisez jamais les lits sans les fonds. Matelas : L'épaisseur du matelas doit être telle que la distance de la surface du matelas jusqu'à la partie supérieure du cadre du lit soit au moins 160 mm. L'épaisseur maximale du matelas est indiquée sur un des pieds du lit par un trou de 3 mm de profondeur. Utilisez un matelas de 200x90x15H cm ou 190x90x15H cm selon la commande et ne superposez jamais deux matelas.

Ne pas laisser dans le lit un objet quelconque pouvant servir de point d'appui à l'enfant. Ne pas laisser traîner des objets pouvant être avalés par l'enfant, pouvant ainsi l'étouffer ou présenter un danger de strangulation. N'accrochez pas d'objets au ou par-dessus le lit et n'en mettez pas contre le lit.

Ne placez jamais le lit à proximité d'une source de chaleur, comme un chauffage électrique, un chauffage au gaz, etc., afin d'éviter tout risque d'incendie.

*Ce lit répond aux exigences de sécurité décrites dans la norme EN 747:2012.*

**NE: INSTRUCTIES VOOR VEILIG GEBRUIK - LEES AANDACHTIG EN BEWAAR VOOR TOEKOMSTIG GEBRUIK.**

Het bovenste bed is niet geschikt voor kinderen onder de zes jaar. Zij kunnen uit het bed vallen en zich kwetsen.

Kinderen kunnen gekneld geraken tussen het bed en de muur. Om het risico op ernstig letsel te voorkomen dient de afstand tussen de bovenste veiligheidsleuning en de muur minder dan 75 mm of meer dan 230mm te bedragen. Monteer het kinderbed zorgvuldig volgens de onderstaande instructies.

Lees zorgvuldig de instructies voor de montage van de ladder. Wijzig niets aan de vormgeving en de montage van dit bed.

Controleer alvorens de ingebruikname van het bed of alle onderdelen zich in goede staat bevinden, goed aangespannen zijn en geen scherpe randen vertonen, waardoor het kind zich kan kwetsen of blijven hangen met zijn klederen (of koordjes, halssnoer, en lintje van de zuigspen), wat een gevaar voor wurging betekent. Controleer alle verbindingpunten.

Controleer het bed regelmatig op onderdelen die gebroken, vervroongen of verdwenen zijn. Bij vaststelling ervan, het bed niet meer gebruiken.

Vervanging van onderdelen : Gebruik steeds originele onderdelen, te verkrijgen bij de fabrikant of verdeler van dit bed.

Gebruik de bedden nooit zonder hun bodem.

De dikte van de matras moet zodanig zijn dat afstand tussen de bovenkant van de matras en de bovenzijde van de bedrand minimaal 160 mm bedraagt. De maximale dikte voor het matras is aangegeven door een gat , 3 mm diep, op één van de bedstijlen. Wij raden een matras van 200x90x15H cm of 190x90x15H cm aan, volgens de afmeting van het bed. Plaats nooit twee matrassen op elkaar.

Laat geen voorwerpen in het bed liggen, waar de baby kan opklauteren, of die de baby kan inslikken en waardoor hij zou kunnen verstikken. Hang geen voorwerpen aan of over het bed en plaats er geen tegen.

Plaats het bed niet bij een warmtebron, zoals bijvoorbeeld elektrische verwarming, gasverwarming enz., om brandgevaar te vermijden.

*Dit bed voldoet aan de veiligheidsvoorschriften omschreven in de norm EN 747:2012.*

**EN: IMPORTANT - KEEP FOR FUTURE REFERENCE - PLEASE READ CAREFULLY.**

The upper bed is not suitable for children under six years due to the risk of injury from falls.

Children can become trapped between the bed and the wall. To avoid risk of serious injury the distance between the top safety barrier and the wall shall not exceed 75 mm or shall be more than 230 mm.

Assemble the bed following the instructions hereunder. Read carefully the instructions regarding positioning and connection of the ladder.

Do not change the design and the assembly method of this bed.

Before putting into use, check if all parts of the bed are in good condition, well tightened, and do not show sharp edges which may injure the child or snag on its clothing (or cords, necklaces, ribbons), causing a strangulation hazard. Check all connection points. Regularly check the bed for broken, warped or missing parts. In such a case, no longer use the bed.

Replacement of parts: Always use original parts, to be obtained from the manufacturer or the distributor.

Do not use this bed without the bottom panel.

The thickness of the mattress must be so that the distance between the upper side of the mattress and the upper side of the bed is minimally 160 mm. The maximum thickness of the mattress is permanently marked by a 3 mm hole on a bed post. We recommend a mattress of 200x90x15H cm or 190x90x15H cm according to the order. Do not put two mattresses on top of each other.

Do not leave anything in the bed which could provide a foothold or create a danger of suffocation or strangulation. Do not hang anything on or over the bed, do not place anything against the bed.

Do not place the bed near a heat source such as electrical heating, gas heating, etc. in order to avoid any fire hazard.

*This bed meets the safety prescriptions provided in the EN 747:2012.*



**DE: SICHERHEITSHINWEISE - FÜR SPÄTEREN GEBRAUCH AUFBEWAHREN - SORGFÄLTIG LESEN.**

Das obere Bett ist nicht geeignet für Kinder unter sechs Jahren wegen der Gefahr von Verletzungen durch den Sturz aus dem Bett. Kinder können zwischen dem Bett und der Wand eingeklemmt werden. Um das Risiko von schweren Verletzungen zu verringern, muss der Abstand zwischen dem oberen Sicherheitsgitter und der Wand weniger als 75 mm betragen oder mehr als 230mm. Bauen sie das Bett zusammen gemäß untenstehende Anleitung.

Lesen Sie sorgfältig die Anweisungen zur Montage der Leiter. Ändern Sie nichts an der Formgestaltung und der Montage dieses Bettes. Überprüfen Sie vor Gebrauch des Bettes, ob sich alle Teile in gutem Zustand befinden, gut angedreht sind und keine scharfen Ränder aufweisen, an denen das Kind sich verletzen könnte oder es mit der Kleidung hängen bleiben könnte (oder Kordeln, Halskette und Band des Schnullers), wodurch es ein Erhängungsrisiko gibt. Kontrollieren Sie alle Verbindungsstellen.

Überprüfen Sie das Bett regelmäßig angesichts zerbrochener, verzerrter oder verschwundener Teile. Bei Feststellung solcher Mängel sofort den Gebrauch des Bettes unterbrechen.

Austausch von Unterteile : Gebrauchen Sie nur Originalteile. Zu erhalten beim Hersteller oder beim Vertriebsgesellschaft.

Bitte die Betten niemals ohne Boden verwenden.

Die Dicke der Matratze muss so sein dass der Abstand zwischen die obere Seite der Matratze und die obere Bettkante höher ist als 160 mm. Gebrauchen Sie eine Matratze von 200x90x15H cm oder 190x90x15H cm laut ihre Befehl. Die maximale Dicke der Matratze ist angegeben von eine Loch der 3 mm auf einem Bettgestell und gebrauchten sie niemals eine zweite Matratze in die Betten.

Keine Gegenstände, die als Stütze für das Kind dienen könnten, im Bett liegenlassen. Keine Gegenstände, die das Kind in den Mund nehmen könnte und wodurch es ersticken könnte, im Bett hinterlassen. Hängen Sie keine Objekte ans Bett oder obendrauf und stellen Sie keine Gegenstände gegen das Bett.

Seien Sie sich der Gefahren und Risiken von offenem Feuer und anderen Quellen starker Hitze, wie Elektrizität, Gas- Feuer, usw. in der Nähe der Krippe bewusst.

*Dieses Bett entspricht den im Standard EN 747:2012 beschriebenen Sicherheitsvorschriften.*

**IT: IMPORTANTE - DA CONSERVARE PER ULTERIORI CONSULTAZIONI - A LEGGERE ATTENTAMENTE**

*Questo letto è conforme alla normativa EN 747:2012*

Avvertenze: Il letto superiore non è consigliato per i bambini sotto i 6 anni, visto il rischio d'infortunio dovuto alle cadute dal letto. I bambini possono rimanere chiusi tra il letto e il muro.

Per diminuire il rischio di ferite gravi, la distanza tra le sbarre di protezione superiore e le pareti devono essere inferiori a 75 mm o più di 230 mm.

Dovete montare il letto seguendo le istruzioni sotto descritte. Leggete attentamente le istruzioni per il montaggio della scala. Mai modificare il design e il montaggio del letto.

Prima di usare il letto, controllare che tutti i pezzi siano in un buon stato, bene chiusi e non presentino bordi taglienti dovè il bambino potrebbe ferirsi o rimanere impigliato con i vestiti.

Con certi accessori (lacci, cordine, collane, catene per succhiotti) incorre un rischio di stangolamento.

Controllare tutti i punti di congiunzione del letto per individuare l'eventuale presenza di pezzi rotti, storti o mancanti. Se è il caso, mettete il letto fuori uso. Rimpiazzamento dei componenti: utilizzare sempre dei pezzi di ricambio originali, reperibili dal fabbricante o distributore.

Mai utilizzare i letti senza il fondo ossia la base.

Materasso: Lo spessore del materasso deve essere tale che la distanza della superficie di lui stesso alla parte superiore dal quadro del letto sia almeno di 160 mm. Lo spessore massimo del materasso è indicata su un piede del letto con un foro di 3 mm di profondità. Utilizzate un materasso di 200 x 90 x 15 cm O 190 x 90 x 15 cm secondo il vostro ordine, e mai sovrapporre 2 materassi.

Non lasciare qualunque oggetto che possa dare appoggio al bambino. Non lasciare in giro oggetti che potrebbero essere ingeriti ed indurre rischio di soffocamento o strangolamento. Non attaccare oggetti sopra o contro il letto.

Non piazzare il letto vicino ad una fonte de calore, come riscaldamento elettrico o a gaz, etc, per evitare il rischio d'incendio.

**ES: IMPORTANTE - A CONSERVAR PARA FUTURAS CONSULTAS - LÉASE ATENTAMENTE**

Preste atención cuando niños (menores de 6 años) utilizan la cama a causa del riesgo de caerse de la cama!

El espacio entre litera y pared no debe ser superior a 75 mm, o debe ser más de 230 mm. Por favor observe estas medidas ya que de lo contrario su niño podría quedar aprisionado entre cama y pared.

Verifique de tiempo en tiempo los ensamblajes con tornillos y, en su caso, vuelva a apretarlos para que la estabilidad de la estructura no sufra menoscabo. De ningún modo utilice la cama si faltase o se hubiese roto cualquier elemento constructivo.

El espesor del colchón elegido debe tener unas dimensiones tales, que la altura interna (es decir desde la superficie del colchón hasta la parte superior de la estructura de la cama) sea al menos de 160 mm. Este nivel máximo es localizable por un hoyo de 3mm de profundidad en la cabeza de la cama.

Esta cama es fabricada para recibir un colchón de 200x90 cm o 190x90 cm según su mando.

No utilizar más de un colchón en la cama.

Preste atención a que en la cama alta o de pisos no se hayan sujetado o colgado cuerdas, cordones, correas o cintas. Su niño podría estrangularse.

Tener presente el riesgo de situar la cuna cerca del fuego o de otras fuentes de calor, tales como aparatos de calefacción eléctricos, de calefacción a gas, etc.

*Producto conforme a las normas europeas EN 747:2012*



重要。请仔细阅读及保留。

1. 上铺不适合六岁以下的儿童，因为有跌倒受伤的风险，
2. 为了避免儿童可能被困在床和墙壁之间受伤的风险，顶部安全栅和墙体之间的距离不得超过75毫米，或应超过230毫米，
3. 请按照官方说明组装床，仔细阅读关于梯子定位和连接的说明，请勿更改此床的设计和组装方法，
4. 在使用之前，检查床的所有零部件是否处于良好状态？是否拧紧？并且没有出现可能伤害儿童的锋利边缘，或是卡住衣服（绳索、项链、丝带上）造成勒绞的危险。一定要检查所有连接点，定期检查床是否有破损、翘曲或缺失的部件，如果出现上述缺失，请立即停止使用该床，
5. 如需更换零部件，请洽制造商或经销商，使用原装零部件，
6. 请勿在没有底板的情况下使用这张床，
7. 床垫厚度需确保至少为200毫米（床垫上侧和床上侧之间的距离）。床垫的最大厚度提示，会以一公分长的刻线标注在树屋床后方、内侧、右角落。我们推荐200x90x15毫米或190x90x15毫米的床垫。不要将两张床垫放在一起，
8. 不要在床上留下任何可能提供立足点或造成窒息或勒绞危险的物品。不要把任何东西放在床上、悬挂在床上或是依靠在床边，
9. 不要将床放在热源附近，如电加热、燃气加热等设备，以避免任何火灾危险。该床符合GB 24430- 1中提供的安全规定。